

## SEA FROST TRADEWINDS AIR COOLED XP with AEO INSTALLATION INSTRUCTIONS

### CONDENSING UNIT LOCATION AND MOUNTING

The design of the TRADEWINDS allows placement of the air-cooled unit in an enclosed space such as a cabin locker or sail locker. Allow 1.5 inches of clearance between the back of the unit and any obstruction. Air flows through the condensing unit and out the back. Intake air should be drawn in from the cabin area to insure the coolest, driest air supply. Intake ducting from the exterior of the boat may cause damp salt air to be drawn in which might reduce unit life. This will also increase below deck moisture. Standard 4" duct hose may be used. A vent must be installed in the area to allow warm air to escape.

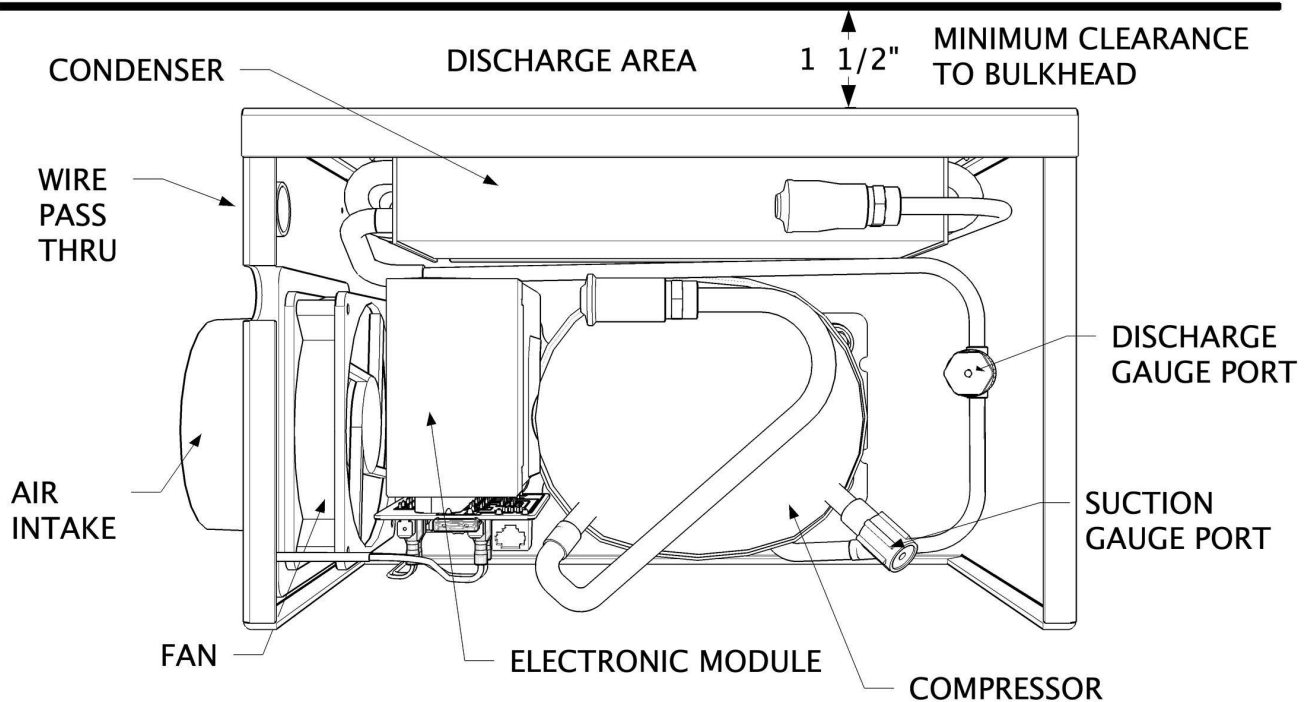

An un-ducted unit in a poorly ventilated small space will heat the air, thereby lowering the capacity of the unit and possibly causing damage by over-heating the compressor.

Service access and installation requires that the front, top, and left end should be accessible. The duct hose will require 4 inches of clearance past the end of the unit.

Mount the TRADEWINDS level. (The compressor is at the bottom). The unit may be platform mounted. Holes have been drilled through the bottom of the housing for fastening to a platform.

## **INSTALLATION REQUIREMENTS**

The air inlet should never be blocked.

- Provide for driest, coolest air for intake.
- Total combined air duct length should not exceed six feet.
- For intake through a finished panel, order a black 4" flange grill.

## **EXPANSION VALVE**

Connect the expansion valve to either of the 3/8" tubes on the plate or in two plate systems one of the tubes on one of the plates.

The valve should be located to allow access to the screw cap on top of the valve. It is preferable that the cap be up.

Trim the tube ends on the plate as necessary. However, allow at least 3/4" to insert into the fitting. Refer to the Swagelok installation instructions in the following pages.

The expansion valve can be mounted inside the box or outside. *If it is mounted outside it will need to be insulated with cork tape and foam to prevent unwanted sweating and dripping.*

## **JUMPER**

Two plate systems will need a 3/8" jumper line between the plates.

## **THE RECEIVER FILTER DRIER (RFD)**

**Note: Unpack and fit the RFD last and at the time of evacuation and charging to prevent saturating the desiccant with moisture.**

Mount the RFD external to the TRADEWINDS cabinet, connecting to the 1/4" liquid line. It must be mounted vertically with the fittings at the top. It is fitted with a sight glass for checking the charge. This glass is best viewed looking straight into the top. Install the RFD in a location that allows proper viewing of the sight glass. The RFD must be installed in the proper flow direction. Connect the tube from the compressor to the in side of the RFD. The out connects to the tube that connects to the valve.

## **RUNNING TUBING LINES**

Two copper lines connect the plate (or plates) and the compressor. One is 3/8" and the other is 1/4".

Run the 1/4" liquid line between the condensing unit area and the expansion valve. This 1/4" line makes up at the expansion valve. The externally mounted receiver filter drier will be fitted to this line. The 3/8" line connects to the un-connected plate tube end (or second plate) with a 3/8" fitting. The other end of this 3/8" line connects at the compressor.

Run the 1/4" liquid line in contact with 3/8" suction line for at least three feet from the cabinet. Wrap these two tubes tightly together with electrical tape. Insulate this section. This will improve operation and prevent moisture from condensing on the coldest section of these tubes. It is recommended but not required to insulate the remaining length of 3/8" return line to the compressor.

## **CAP TUBE ENDS**

Be sure to keep the copper tubing clean and free of moisture by capping the tubing after each cut with the plastic caps provided.

Support the tubing every 18 inches as necessary using tie wraps fastened with self-taping screws.

**WARNING: The TRADEWINDS unit is shipped with some nitrogen pressure. Before removing the caps on the connection ports, remove the screw caps on the service valve covers and depress the valves cores to vent any existing pressure.**

## **COMPRESSOR CONNECTIONS**

Working one line at a time, remove the Swagelok caps from compressor and condenser fittings. Attach the union fitting bodies. This is a pre-swaged connection; See the Swagelok fittings text in this manual. Make up of these pre-swaged connections is 1/4 turn from wrench snug. Connect the 1/4" line to the condenser fitting and 3/8" line to the compressor. Tighten these fittings 1-1/4 turns from *wrench snug*.

## NOTES ON SWAGELOK FITTINGS

Swagelok fittings come to you completely assembled, finger-tight. (Pieces a, b, and c in Drawing #1 are already together). They are ready for immediate use.

Disassembly before use can result in dirt and foreign material getting into the fitting and causing leaks and you risk damaging the threads if nuts are removed. If disassembly is necessary, reassemble per drawing.

This is a double ferrule system. The most serious installation problem encountered with SEA FROST is the improper assembly of these fittings. Be sure that you assemble all fittings as in Drawing #1.

To ease assembly slacken the fitting nut slightly before assembly. Then retighten with fingers before tightening with a wrench. (This is to avoid cross threading.)

Step 1. Always leave two inches of straight, undistorted tubing leading to all Swagelok fittings to allow proper connection.

Step 2. Prior to inserting 1/2" tubing into the Swagelok tube fitting, make a pencil mark 1" from end of tube. Prior to inserting 3/8" tubing, make a pencil mark 3/4" from the end of the tube. With 1/4" tubing make a mark 5/8" from the end.

Step 3. Insert clean, smooth tubing with the pencil mark into the Swagelok tube fitting. You can be sure the tube is resting firmly on the shoulder of the fitting when the pencil mark is flush with the nut. This mark will also indicate that the tube has not moved before tightening. (As the fitting is tightened the space from the pencil mark to the shoulder will increase.)

Step 4. Tighten the Swagelok nut to a wrench snug\* position. Scribe the nut with a pencil at the 6:00 o'clock position (see drawing #1, step # 2).

\* Wrench snug is the first point in the assembly tightening when the tube cannot be pulled from the fitting, (i.e. when the ferrules tighten enough to contact the tubing).

Step 5. Now, while holding the fitting body with a back-up wrench, tighten the nut one-and-one-quarter turns ( 1-1/4). To do so, watch the scribe mark, make one complete revolution, and continue to the 9:00 o'clock position. (See drawing #1, step #3).

**DRAWING 1**



STEP 1

Simply insert the tubing into the SWAGelok tube fitting. **Make sure that the tubing rest firmly on the shoulder of the fitting and that the nut is wrench snug.**

STEP 2

Before tightening the SWAGelok nut, scribe the nut at the six o'clock position.



STEP 3

Now, while holding the fitting body steady with a backup wrench, tighten the nut 1 1/4 turns. Watch the scribe mark, make one complete revolution and continue to the 9 o'clock position. By scribing the nut at the 6 o'clock position as it appears to you, there will be no doubt as to the starting position. When tightened 1 1/4 turns to the 9 o'clock position you can easily see that the fitting has been properly installed.



SWAGELOK FITTINGS ARE TO BE TIGHTENED TO A TORQUE SPEC, NOT INFINITE TIGHTNESS. BE SURE YOUR STARTING POINT IS WRENCH SNUG. A DISTORTED TUBE MIGHT GIVE A FALSE STARTING POINT.

\* When making all connections, USE TWO WRENCHES. Don't allow the fittings to turn or twist when tightening.

### RECONNECTING PRE-SWAGED FITTINGS

Connections can be disconnected and retightened many times.

When reconnecting, insert the tubing with pre-swaged ferrules into the fitting until the front ferrule seats in the fitting. Tighten the nut by hand. After tightening to wrench snug, rotate the nut about one-quarter turn with a wrench.

### SWAGELOK PERFORMANCE

Swagelok fittings have built-in spring interaction between the ferrules. This compensates for temperature changes and allows the fittings to be reconnected many times. As the fitting is tightened, a burnishing occurs between the body of the fitting and the ferrules and between the ferrules and the tube. This action provides the tightest connection available.

### MOUNTING THE EVAPORATOR PLATE (on some systems)

The Sea Frost BD plate mounts with a Wellnut expandable neoprene blind hole fastener. A template or the plate itself should be used to locate the mounting holes. Drill a 3/16" pilot hole. Increase this hole to 3/8".

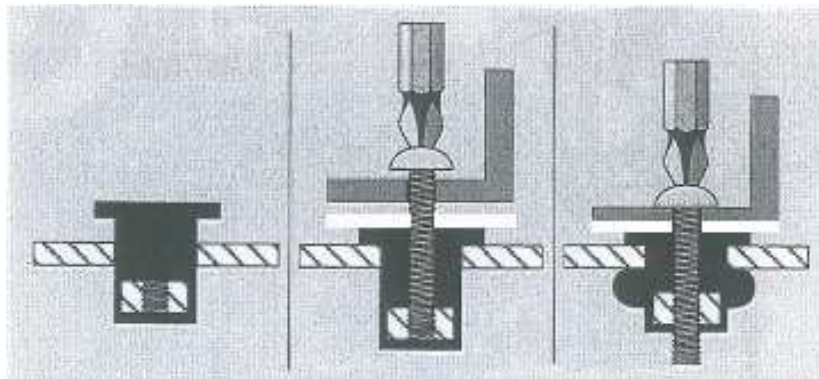

1. Place Well-nut insert all the way into Pre-drilled hole until flange is firmly against mounting surface.	2. Pass Machine screw through part to be fastened and the white spacer washer.	3. Tighten until snug.
---	--	------------------------

## REMOTE THERMOSTAT INSTALLATION & WIRING

For the best looking job, the thermostat should be recessed into a panel. A cutting template is provided. Locate the thermostat close enough for the bulb on the sensing tube (pig tail type coil) to reach a mounting ear on the plate. On **two plate systems** the bulb must be attached to the second plate. This is the plate without the valve. It is necessary that the bulb end of the sensing tube be in excellent thermal contact with the plate. Neatly coil any extra sensing tube in the box and secure with ties.

*The sensing tube is hollow; avoid bending it into kinks.*

### Aluminum Holdover Plates:

Attach the thermostat bulb to the plate using the stainless steel clip. Use one of the existing plate mounting screws as an attachment point. Neatly coil any extra sensing tube in the box and secure with ties.

### Aluminum Block:

Attach the bulb to the center of the bottom of the block using a 1/4"- 20 x 1/2" pan head into the pre-tapped hole.

### Stainless Steel Evaporator plates:

Slide the bulb clip onto the edge of the plate and over the sensing bulb as shown in the drawing to the right. The sensing bulb must be in excellent thermal contact with the plate. We recommend that the probe be mounted on the plate in the one of the lower mounting positions as shown in the drawing below. This is best because these positions remain colder

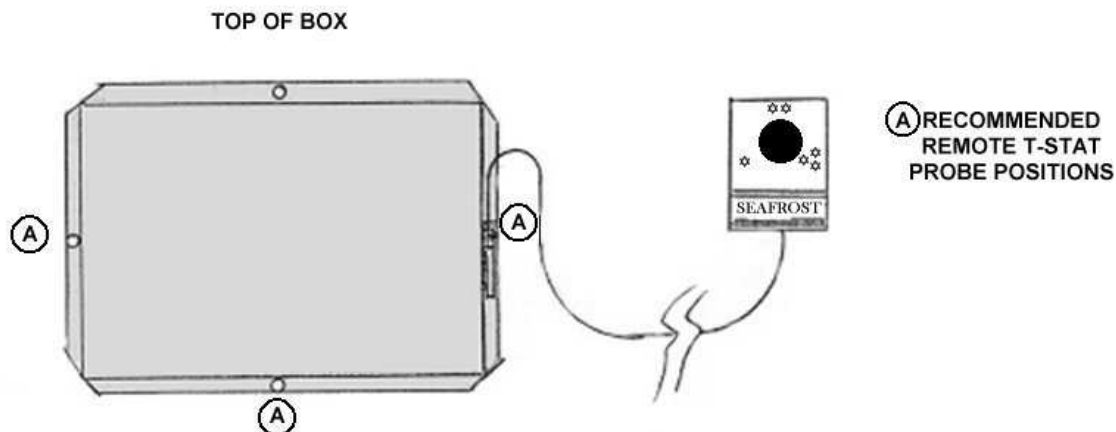
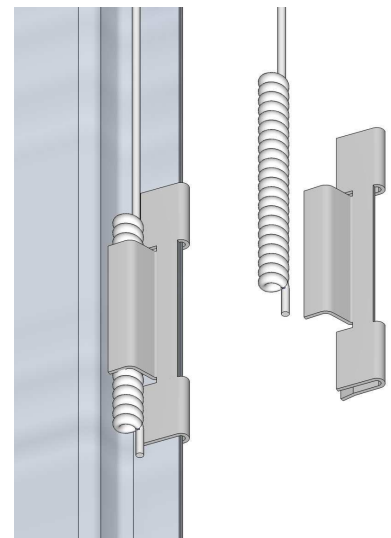

The SEA FROST BD thermostat is variable. Turning the knob fully counterclockwise turns the unit "OFF". The full clockwise setting is the coldest. The thermostat may be adjusted to obtain any temperature desired in the cabinet. The thermostat may be calibrated should the warmest setting be too cold. To calibrate the thermostat remove the mounting screws and tip the panel forward. Remove the electrical tape (if necessary) the adjustment screw about an inch into the case.

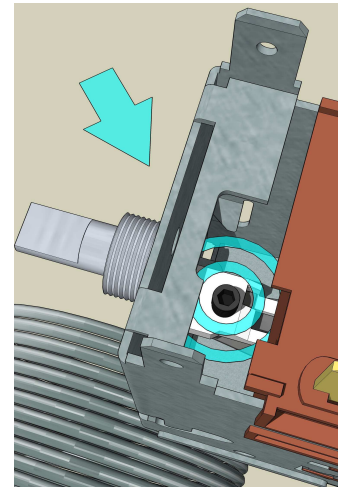

To lower box temperature, rotate this screw counter clockwise. One full revolution will change the box temperature approximately 6 degrees F. To raise the temperature in the box rotate the screw clockwise. Make small adjustments. Record all adjustments.

## STANDARD THERMOSTAT WIRING

Connect the thermostat wires at the compressor module to terminals T & C using female 1/4" female crimp connectors. This is for AEO operation. There is no polarity requirement.

Remote (snowflake panel) thermostat wires ~ red.

Electronic thermostat thermometer (version 1) wires ~ green and white

Electronic thermostat thermometer (version 2 & 3) cat 5 data cable with RJ 45 connector. Install a 3-amp ATC fuse in the fuse holder on the Module PCB board. **The PBC board fuse is required only if using Electronic Thermostat with the RJ-45 jack.**

## ELECTRONIC THERMOSTAT THERMOMETER (Option)

Follow the detailed instructions provided with the ETT.

If using the Electronic Thermostat Thermometer, the wires will be green and white.

## CONNECTIONS

For best performance, the electronic module should be connected directly to the battery or battery selector switch. Connecting the module through the boat's breaker panel may cause a voltage drop; small wires and multiple connectors create resistance. If using the ships panel check the integrity of all the connections and wire size including the ground buss feed.

## WIRE SIZE

12-volt installations use AWG #10 wire for distances up to 10 feet from battery supply (20' roundtrip), and #8 AWG wire for distances up to 25 feet from battery supply (50' roundtrip). **Fuse 30 Amps.**



24 Volts: The unit is the same, the module will self calibrate to the applied voltage and provide proper fan voltage. **Fuse 15 Amps.**

**Calculate wire size** based on the fuse size and a 3% voltage drop. Follow ABYC wiring guidelines for proper, safe wiring. In any application, use the next largest wire if in doubt to prevent a voltage drop. A fuse is preferred over a breaker as it has less potential voltage drop. Connect a red wire from 12 or 24 volts positive to the (+) terminal of the module. Connect a black or yellow wire from 12 or 24 volts negative to the (-) terminal of the module. Do not operate the TWxp directly from a charger without a battery. Never apply power to any of the other terminals.

### WIRING DIAGRAM

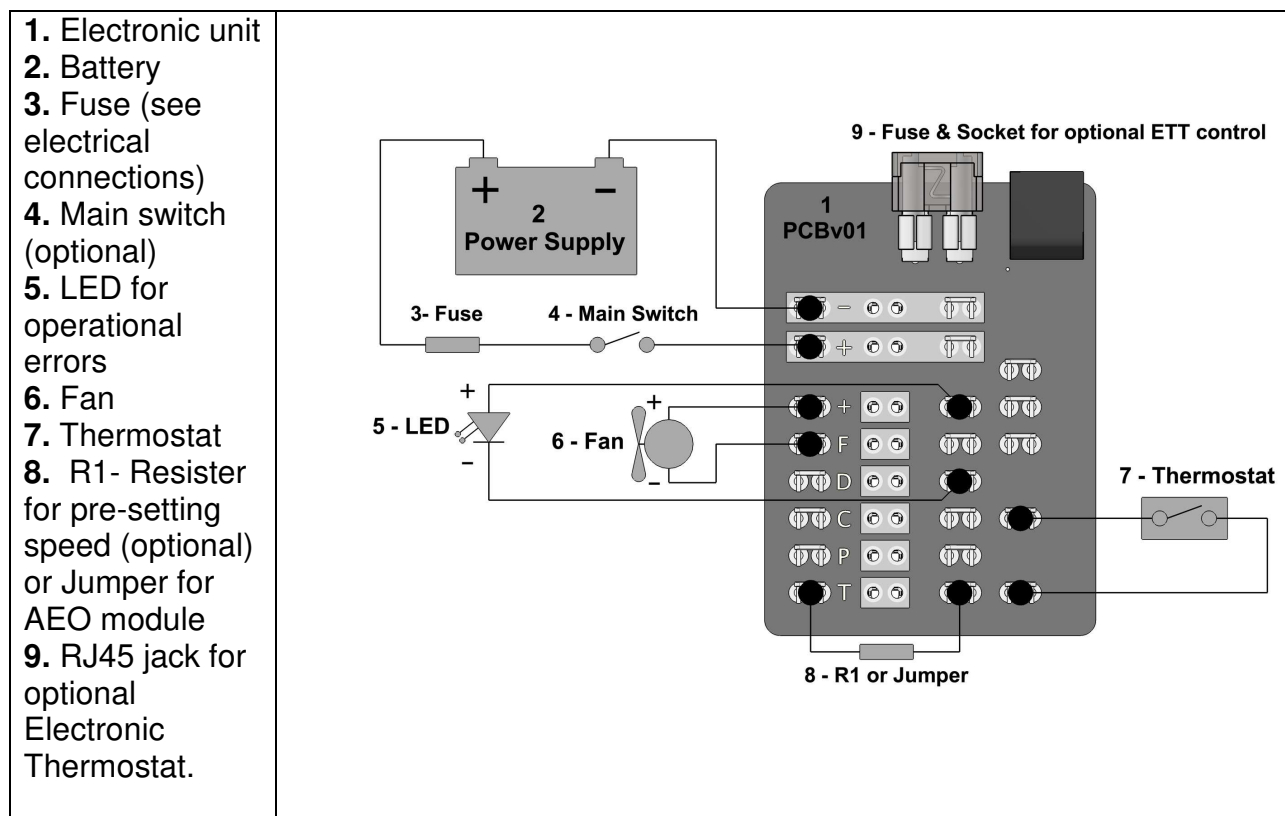

**NOTE:** When using the modular thermostat connection (#9) there are no connections on thermostat terminals (#7).

### COMMISSIONING

Attach clean, purged R-134a gauges. The blue hose connects to the suction service port on compressor. This is the blue-capped tube stub on the compressor. The red hose connects to the red-capped port on the discharge line.

## CHECK FOR LEAKS

Refer to the refrigerant handling section of this instruction manual then return to this page.

**CHARGE:** This system operates with refrigerant R-134a. The proper charge amount is 6-12 oz.

 **WARNING!** Do not use refrigerant with any additives, including but not limited to: oil, dye, and leak stop.

This may be liquid-fed into the low side after evacuation, before the compressor is operated. An automatic expansion valve regulates the evaporator pressure. This valve is adjusted to maintain a constant evaporator pressure. The proper charge must be added before the valve can be accurately set.

## ADJUSTING THE VALVE

Before operating the compressor, unscrew the plastic cover on the valve body. Note the adjusting knob. Counter-clockwise rotation decreases the pressure. Clockwise rotation increases the pressure. One turn should equal a 2-psi pressure change. Check that the valve is set in the "0" position. The "0" position is when the top thread on the valve adjustment knob is even with the valve body. See drawing below.

Start the compressor. The valve must be adjusted to a 0 to 2 psi reading on the low side gauge port. Be sure your gauge is set at 0 before hook-up. Allow several minutes between each adjustment. Moisture may form on the adjusting knob side of the valve and freeze causing the valve to malfunction. To prevent this, replace the cap after each adjustment. Be sure the valve is dry before final cap replacement. Operate for 30 minutes to confirm proper valve setting and operation.

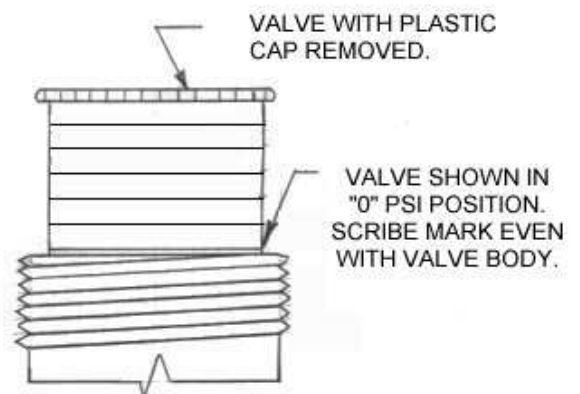

The valve may need to be cleared of dirt or chips if adjustment is not possible. With the compressor running, turn the valve adjustment knob clockwise about 3 turns momentarily, and then back to the proper setting. Do not leave the valve in open position (allowing high backpressure) as this may cause the compressor to overload.

After satisfactory adjustment, turn off the thermostat. Remove the gauges. Recap the service ports. Replace the service panel. When the valve has dried, insulate the valve body (if it is outside the box) by wrapping it with foam and cork tape. This is to prevent

condensation. Also insulate the one-foot section of 3/8" tubing that exits the cabinet. The valve need not be insulated if the valve is in the icebox.

**Trouble shooting note:** The operating pressure of the system **will not** indicate the amount of refrigerant in the system. The valve will not give proper operation or pressure if it is undercharged. Check the valve scribe line. It should correlate to gauge pressure.

The system requires enough refrigerant to supply liquid to the valve. If the valve has a steady hissing sound then the charge is okay. If the valve is sputtering then it is low. If the valve is making a noticeable roar it is empty. If the low side pressure is properly set the high side pressure will be 80 to 135 psi. depending on the air temperature (50 to 95 degrees F.) through the unit. Almost immediately upon start up the valve body will begin to frost.

## **OPERATION DESCRIPTION**

The SEA FROST TRADEWINDS is a small system. It is efficient in its electrical conversion of energy to heat movement. It's rate of cooling is 1/20<sup>th</sup> the rate of the Engine Drive system. By being small it is quiet, compact, has low electrical starting requirements and running power draw. The TRADEWINDS will operate in up to 120 degrees of ambient air temperature. Because of its size it may operate 70 percent of the time if cooling larger boxes in warm climates. The unit will freeze the holdover plate from warm but may take all day. If rapid cooling of the system is needed operate the Engine Drive to bring the system to its cooling temperature then let the TRADEWINDS take over. The unit will automatically operate if the thermostat is on and 12 VOLTS D.C. is available. The system may be operated using the shore power charger to maintain the batteries. The TRADEWINDS and the Engine Drive are separate units and may be operated simultaneously. Both units are controlled by separate controls.

## **DEFROSTING**

Excessive frost/ice build up on the plate or block will reduce the cooling effect. Allowing the unit to warm above freezing is one method of defrosting. Warm water or a hair dryer is also a quick method. The SEA FROST plates can be scraped with a spatula or ice scraper to remove excessive frost build up.

## **OPERATION INSPECTION**

Within a few minutes of starting the TRADEWINDS, tubing in close proximity to the valve and the valve itself will be noticeably cold. **If after 20 minutes of operation cooling in this area is not observed do not continue to operate the system.**

## OPERATIONAL INFORMATION

<b>VOLTAGE:</b>	12 D.C. or 24 D.C.
<b>AMP DRAW:</b>	3.3-14 @ 12 VOLTS 2 to 7 @ 24 VOLTS
<b>WIRE SIZE TO BATTERY SUPPLY: FOR 12 VOLT OPERATION</b>	AWG # 10 up to 10' (20' round trip) AWG # 8 up to 25' (50' round trip)
<b>LOW VOLTAGE CUT-OFF</b>	10.4 VOLTS / 12 VOLTS 22.8 VOLTS / 24 VOLTS
<b>FUSE MAX INSTALLED AT BATTERY</b>	12-VOLT -30 AMP STANDARD AUTOMOTIVE 24-VOLT - 15 AMP STANDARD AUTOMOTIVE

**SERVICE NOTE:** The TRADEWINDS is intended to operate with the cover in place. When operating with a manifold gauge set, be sure to block off the top and front with cardboard and tape to maintain proper airflow to the condenser.

## TROUBLESHOOTING

A light emitting diode (LED) is connected between terminals **+** and **D**. In case the electronic unit records an operational error, the diode will flash a number of times. The number of flashes depends on what kind of operational error was recorded. Each flash lasts 1/4 second. After the actual number of flashes there will be a delay with no flashes, the sequence for each error recording is repeated every 4 seconds. Flashes will only occur in the fault mode with the system on.

See additional trouble shooting information available at [www.seafrost.com](http://www.seafrost.com)

### OPERATIONAL ERRORS SHOWN BY LED

Number of flashes	Error type
5	<b>Thermal cut-out of electronic unit</b> (If the refrigeration system has been too heavily loaded, or if the ambient temperature is high, the electronic unit will run too hot.)
4	<b>Minimum motor speed error</b> (If the refrigeration system is too heavily loaded, the motor cannot maintain minimum speed 1,850 rpm.)
3	<b>Motor start error</b> <b>A.</b> (The system might be overcharged.) Has charge been added? <b>B.</b> Faulty module. <b>C.</b> This fault may also occur when the compressor is trying to start a warm system or on initial start up on a new system. Several attempts and then start up can be normal. <b><i>Do not let out refrigerant until first contacting Seafrost!</i></b>
2	<b>Fan over-current cut-out</b> (The fan is defective.)
1	<b>Battery protection cut-out</b> (The voltage is outside the cut-out setting. Low voltage.)

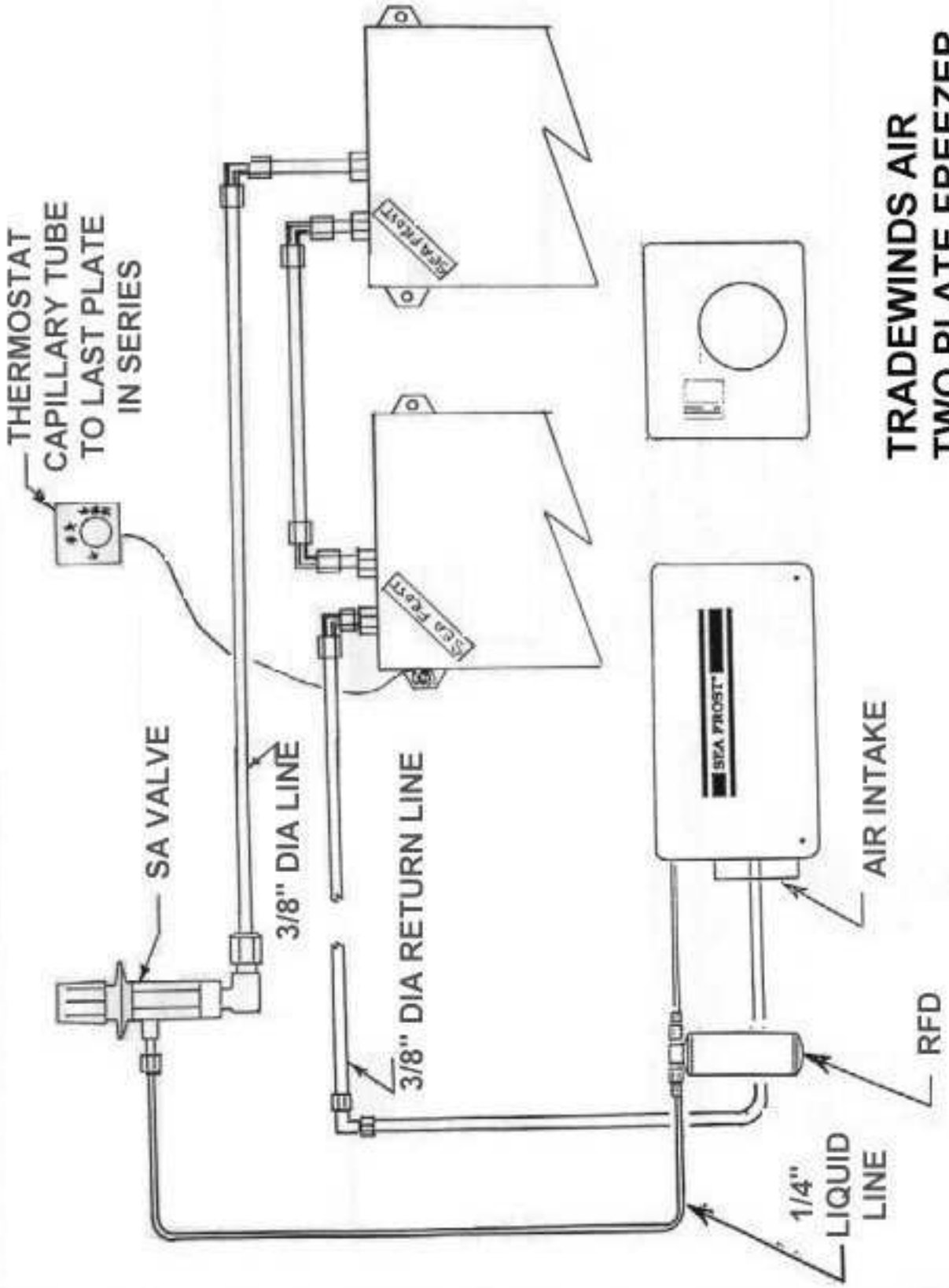

**TRADEWINDS AIR  
TWO PLATE FREEZER**

## THERMOSTAT CALIBRATION INSTRUCTIONS

Note: Be sure that the unit is operating properly before making any thermostat adjustments. The sensing bulb must be in excellent thermal contact with the plate or block.

The range of this control may be changed. To access the adjustment screw, remove the four mounting screws on the thermostat panel. Tip the panel forward and make the adjustment with a torx or small phillips head screwdriver.

Make small adjustments. Record all adjustments.

If the lowest setting on the thermostat panel is too cold:

- Turn the adjustment screw clockwise. One 360-degree turn will raise the box temperature approximately 6 degrees f.

If the highest setting on the thermostat panel is too warm:

- Turn the adjustment screw counterclockwise.

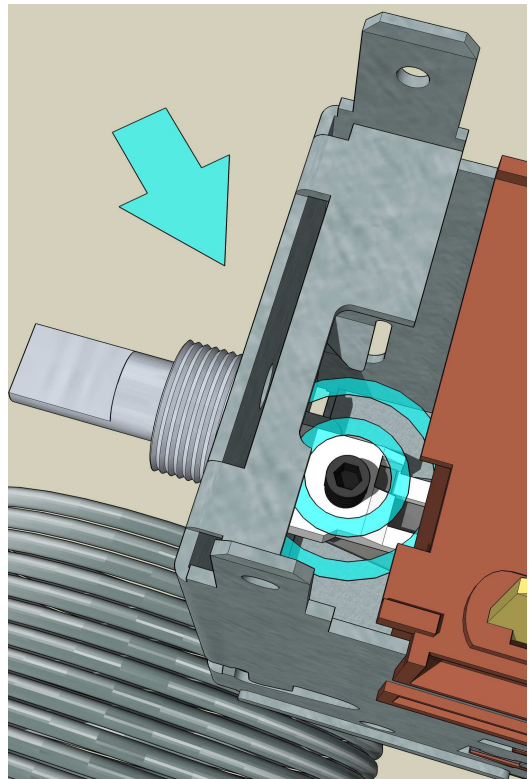

# HOLDOVER PLATES

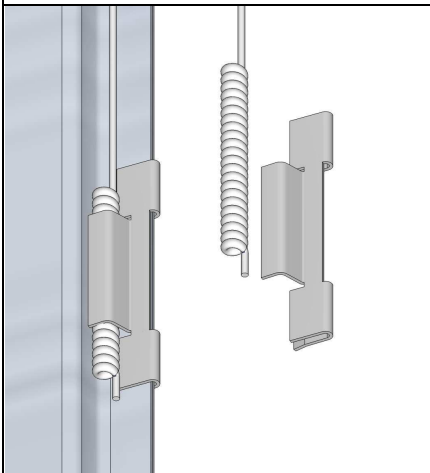
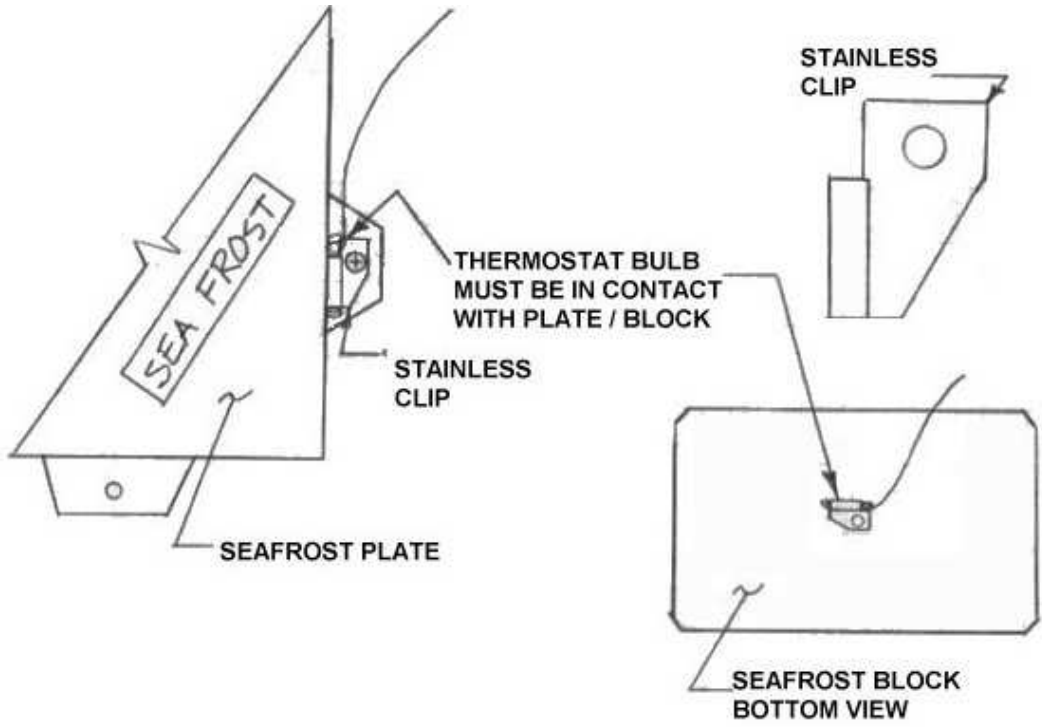

STAINLESS STEEL  
EVAPORATOR PLATES

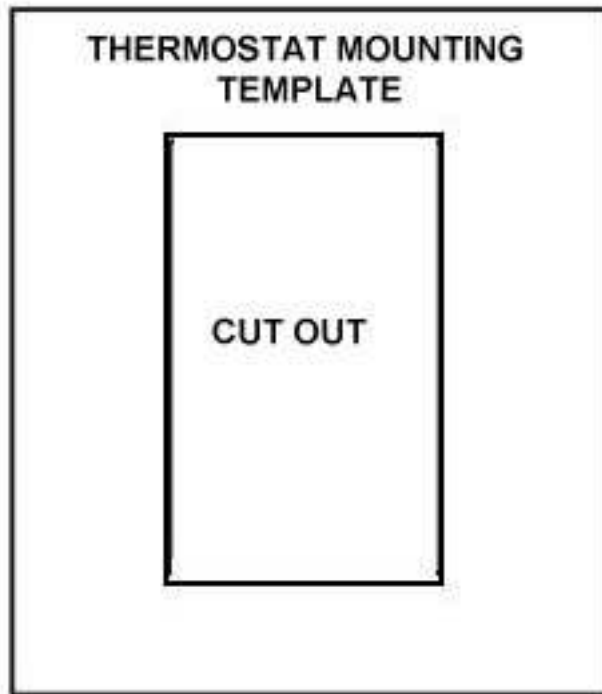



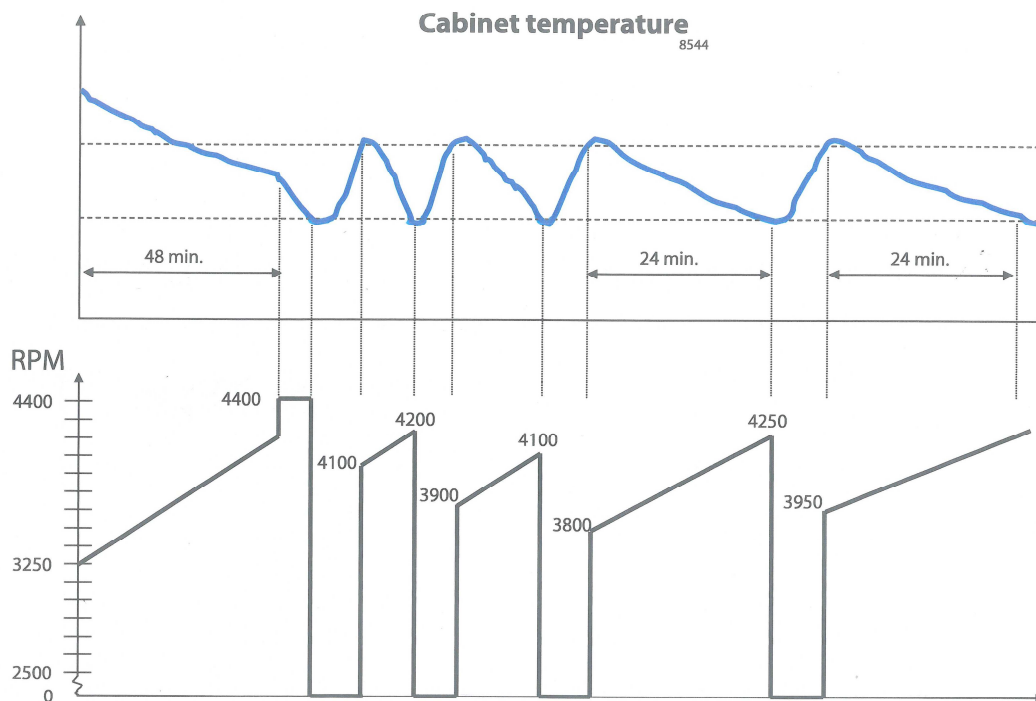

## Adaptive Energy Optimization (AEO) with High Speed Electronit Unit

### Introduction

Herewith a description of a function in the high speed electronic unit. The unit contains a feature called **Adaptive Energy Optimization (AEO)**. It is very suitable for systems with huge load variations and applications where energy is an important issue.

### Function

#### *Initial start up conditions*

Every start up of the compressor takes place at low speed (soft start). The start up speed is equal to: the speed at thermostat cut out minus 300 rpm. After start up the speed of the compressor will be ramped up and adapted to the load. The ramp up speed is 9.4 rpm/min.

#### *Adaptation of the capacity.*

The software algorithm adapts the capacity of the compressor to the actual load of the system.

The unit regulates the capacity so that the compressor runtime is approximately 24 minutes. If the compressor does not reach cut out temperature within 48 minutes the speed is set to 4400 rpm.

#### *Example how to determine the speed*

Start up speed: 3250 rpm  
 Runtime: 15 minutes  
 Speed at cut out:  $3250 + (9.4 \times 15)$   
 ~3390 rpm

Start up speed:  $3390 - 300 = 3090$  rpm  
 Runtime: 20 minutes  
 Speed at cut out:  $3090 + (9.4 \times 20)$   
 ~3280 rpm

Start up speed:  $3280 - 300 = 2980$  rpm  
 Runtime: 30 minutes  
 Speed at cut out:  $2980 + (9.4 \times 30)$   
 ~3260 rpm

### Curves

The graphs on page 2 show the relation between cabinet temperature and speed. After a power cut out the start speed will always be set to 3250 rpm.

After a thermostat cut out the start up speed is calculated as speed at stop minus 300.

The speed will be adapted automatically so that the thermostat runtime will be approximately 24 minutes.

### Benefits

- Independent of load variations
- Energy savings
- Reduced number of compressor starts
- Prevents short cycling of the compressor
- Battery protection
- Soft start in tropical conditions