

SEA FROST®

372 ROUTE 4 BARRINGTON, NH 03825 USA
E-Mail: sales@seafrost.com

TEL (603) 868-5720

FAX (603) 868-1040

1-800-435-6708
www.seafrost.com

**OPERATION & INSTALLATION
INSTRUCTIONS**

**ENGINE DRIVE AIR SYSTEM
12-volt**

**C.F. HORTON & CO., INC.
603-868-5720**

PLANT LOCATION AND MAIL

**372 ROUTE 4
BARRINGTON, NH 03825
USA**

NOTICE OF RESPONSIBILITY

It is the SEA FROST/C.F. Horton & Co., Inc. intent to provide the safest, most accurate and detailed instructions. SEA FROST/C.F. Horton & Co., Inc. cannot be responsible for problems or damage caused by omissions, inaccuracy or interpretation of these instructions.

SEA FROST is a registered trademark of C.F. Horton & Co., Inc

Aspects of the SEA FROST design are covered by US Patent #4,356,708

Copyright © 1994 by C.F. Horton & Co., Inc.

WATER FLOW

The Engine Drive Air Conditioner system is water-cooled. You can use either a belt driven water pump or an electric driven pump.

Belt driven water pump will pump water for this system whenever the engine is running regardless of the operation of the blowers or compressor switch. Water flow should be observed before operation of the system. If no water is flowing and the engine is running with the system switched on the compressor will rapidly cycle.

Electric pumps will operate when the blower is switched on and the thermostat is on if fitted with the thermostat. Check water flow sea strainers regularly.

If the compressor rapidly cycles and no cooling occurs switch off the system and inspect the water system.

OPERATION

With DC power switched on, the air blowers will start and the compressor clutch will engage and cooling will begin. If the system is turned on when the engine is off, the compressor clutch will engage, but no cooling will take place. Normal operating current will be drawn from the battery.

AMPERAGE DRAW

The compressor clutch will draw 3 to 3.5 amps at 12 volts. There is a 7 amp. fuse fitted to the air handler for the compressor clutch. The two blower motors will draw 11 amps each at 12 volts, plus the amp draw of the electric water pump. They should be protected with a proper size breaker. It is important have the electric water pump and blowers on the same circuit.

ROUTINE INSPECTION:

- Check the water intake strainer
- Check the refrigerant charge
- Check belt tension on the compressor and water pump (if belted)
- Vacuum air handler grill to remove lint

NORMAL OPERATION

In normal operation with the engine operating, proper water flow, and the unit switched on cold air will be delivered at the vents. After prolonged operation in high humidity the compressor will cycle off to allow the cooling coil to defrost. Warmer air will be delivered for a few seconds until the defrost cycle is over and the compressor re-engages.

INSTALLATION

Careful installation should be stressed. The performance and life of the system are in the hands of the installer. To insure your work:

1. Read this manual.
2. Reread any aspect you don't understand.
3. Be careful about fitting assembly and installation.
4. Install the RFD last and the same day the system is charged.
5. Spend enough time leak checking to be sure there are no leaks.

Water and dirt contaminants will give you problems in a refrigeration system. Moisture in the air is always present and cannot be eliminated; water in this case refers to puddles and drops. Dirt is any solid. The installer's habits will ensure a trouble-free start-up. We have added a large receiver filter drier (RFD) to take care of all dirt and moisture that may get into the system during installation. Moisture in the system is boiled off when the system is evacuated, or it is captured in the desiccant in the RFD. A screen in the expansion valve prevents dirt from plugging it.

Excess moisture not trapped by the RFD will block the expansion valve with ice. This ice stops the cycle. The only cure is to discharge the refrigerant, replace the RFD, re-evacuate the system, and recharge it. This remedy takes time and is somewhat costly. Keep the system clean and dry.

TUBE HANDLING

Installation is quite simple. All the copper tube comes to you with the ends capped. Any routing of the tubing must be done with the tube either taped or capped. Cap both tube ends after each cut. Spare caps have been included.

Work with only one line at a time, and uncap only one end at a time.

TUBE CUTTING

Use a tube cutter; hacksawing or any other method will introduce chips to the system and also distort the tube, making connections difficult and leak-prone. A miniature cutter is essential for this work. Cut slowly to avoid a ridge on the inside of the tube. We do not recommend reaming or dressing the cut, because chips of copper will get into the system and cause trouble.

TUBE BENDING

Make all but the long sweep bends with a spring bender; one kink and the line must be re-run. Don't add any more fittings than are absolutely necessary. Route all the lines in such a way that they are most direct but out of the way. Always leave several inches of straight undistorted tubing leading to all Swagelok fittings to allow proper connection. **Keep everything sealed until you are ready to make the connection.**

FIT THE CONDENSER / RFD ASSEMBLY LAST

The RFD and condenser assembly should be the last component to be connected. Do not open the connections on the RFD until all other parts are fitted.

AIR HANDLER

The air handler must be located adjacent to the space being cooled. Mount it with the condensate pan parallel to the vessel's waterline. The decorative return air grill should be the same size or larger than the face of the unit (the front of the radiator) with little air restriction from stiles or louvers. *Restricting the airflow will greatly reduce the capacity of this system.* In most applications the unit is mounted low and the two four inch supply hoses are vented high. Condensate water must be able to drain from the pan in the operational position on the vessel.

Do not install the air handler in an engine area, bilge, or locker area with air passages accessible to the bilge or engine room.



Possible death could result from improper installation.

Any air conditioner installed with an air passage to the engine or generator space could distribute deadly exhaust fumes to the living space.

The unit must be installed in the living space of the boat. This includes the closets and under bunks as long as the air space is common to the living space.

- The unit must be mounted level (parallel to the water line).
- The condensate pan must drain properly to prevent any water from spilling into the boat when in the operational attitude.
- Condensate drain must not be open to the engine area.
- An above the waterline drain must not exit within 4 feet of the engine exhaust.
- Loop the drain hose to form a water trap.

THERMOSTAT

A thermostat may be added to the system to maintain even temperatures if the unit is used in a small space or when using it for dehydrating. The thermostat bulb should be plastic tied to the horizontal plastic strip on the front of the air handler. The control panel should be mounted within the distance of the capillary tub length allowing some slack etc. Wire the thermostat with 16-gauge or larger wire to the terminal strip. Remove the jumper to wire the thermostat. See wiring diagram.

THE COMPRESSOR

The compressor is the first component to mount when installing the SEA FROST system

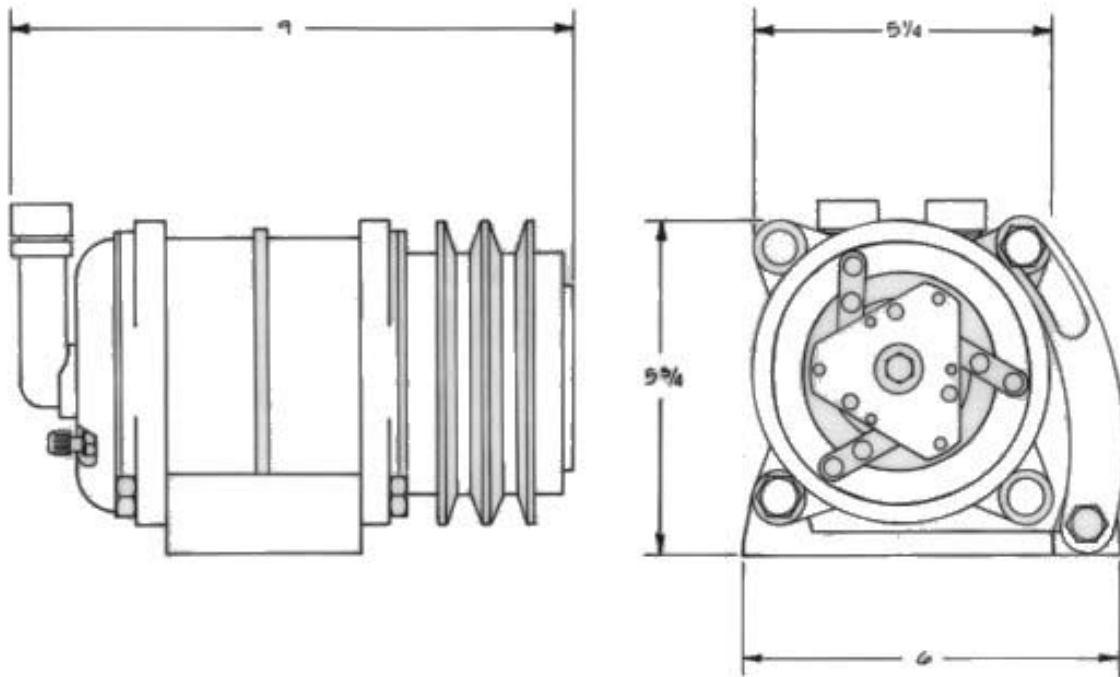

FITTING THE COMPRESSOR TO THE COMPRESSOR BASE

⚠ WARNING: Failure to follow these directions will cause irreparable damage to the compressor and void any claims.

The compressor base bracket must be lightly filed or sanded to properly fit between the mounting "ears" of the compressor. It must be a perfect fit with no force required to slide the bracket onto the compressor and yet have **zero clearance** between the two

parts. Forcing the compressor on to the bracket will spread the ears cracking the compressor case. Extra space will allow the hinge bolt to work and if tightened break the compressor ears.

In determining the compressor location for custom brackets and off engine mounting of the compressor consider all of the following:

COMPRESSOR POSTURE

- ❖ Mount the compressor no more than 45 degrees from vertical. The top of the compressor is indicated by the port fittings, the clutch coil wire, and the ground screw.
- ❖ Allow clearance for the compressor hose assemblies and belt adjustment if the compressor is mounted under the engine.
- ❖ An optional low profile head is available for installations with little top clearance and allows the hoses to exit straight back.
- ❖ We recommend that the compressor be driven by its own belt.
- ❖ A single hi-power "A" belt is all that is required to drive the compressor.
- ❖ A five-inch diameter pulley is required to drive the compressor. The compressor speed ratio should not exceed the crank shaft speed of the engine. This ratio will give proper cooling at a fast idle and also allow operation at cruising RPM's.
- ❖ The compressor will draw up to two horsepower. It should be ruggedly bolted.
- ❖ The extra pulley on the compressor may be used to drive a pump or an alternator.
- ❖ The compressor may be mounted to a fabricated bracket that is bolted to the engine.
- ❖ A jackshaft may be used to drive the compressor.
- ❖ The compressor may rotate in either direction.

OFF-ENGINE MOUNTS

Engine motion is a torsional load, concentric around the crankshaft. At the crankshaft center, the engine is stationary. This allows off-engine mounting of the compressor. Side loads on the clutch pulley do not affect the compressor since the construction of the free wheel pulley puts all load on the compressor case. This protects the compressor bearing and shaft seal from failure and leaks from load. The compressor is a very smooth device and may be hard mounted on the engine beds or other members

attached to the hull. It will not introduce any vibration or noise by this mounting, and in many cases a much stronger mount is possible. The drive belt will not transmit any engine vibration to the boat. The compressor pulley and the engine drive pulley are large and will provide plenty of belt contact without excessive tightening, so off-mounting will not "ground-out" a flex mounted engine.

PULLEY MOUNTING ON ENGINES

It is imperative that the extra pulley be mounted to the engine crank pulley using lock washers or thread lock adhesive / sealant.

Failure to lock attachment bolts will allow the bolts to loosen, causing damage and possible danger from flying parts.

Bolts should be tightened to a torque setting recommended for the diameter and grade of bolt being used.

We recommended adhesive/sealant: Loctite 271 by Loctite corporation of Newington, CT. and Cleveland, OH.

COMPRESSOR BELTS

Various belts are available with an "A" section (1/2"). Specify a high power belt. Fractional horsepower belts will stretch and wear rapidly. Cogged belts and kevlar strand reinforced belts are available but not essential.

Belt length is measured on the back edge of a belt. An easy way to get a belt size is to wrap masking tape around the pulleys with the compressor in the loose position. Break the tape in one place and peel it off. Measure the tape to get the belt length. Once you have determined the belt size, record the brand and part number. Each belt manufacturer has different sizing.

CONDENSER / RFD ASSEMBLY

Install the Condenser close to the water pump and compressor in the engine area. Mount the Condenser/RFD with the two tabs to a suitable platform. Water should enter the 5/8" tube and exit overboard above the waterline from the upper one.

The RFD is has a sight glass on top for viewing refrigerant charge. This glass must be visible for charging and servicing the system. It can be viewed from the top at up to a 45-degree angle but not from the bottom or side. Be sure the sight glass is easily visible!

DO NOT OPEN THE RFD UNTIL ALL THE OTHER CONNECTIONS HAVE BEEN MADE AND YOU ARE READY TO COMMISSION THE SYSTEM.

The RFD contains a desiccant to absorb moisture, because absorption is limited, it is important to make the connections after all other connections are made. Leaving the RFD installed on a partially open system may reduce its absorption capacity by allowing it to absorb moisture in free air before the system is sealed.

ELECTRIC PUMP

If an electric pump is fitted it is critical that the water circuit be proper to keep the pump primed. A forward facing scoop is recommended. The through hull must be as low in the boat as possible with the sea strainer slightly above it. The pump must be above the sea strainer and the pump outlet above the inlet leading up to the condenser. The hose from the condenser should be direct and as straight as possible to the discharge through hull above the water line. Water traps and air pockets in this water circuit will lead to intermittent pumping and damage to the pump and system. The pump must be air free and wet to pump.

SWAGELOK FITTINGS

Swagelok fittings come to you completely assembled, finger-tight and ready to use.

Do not take apart the fittings before you are ready to use them; dirt can get into the fitting and cause leaks. You also risk damaging the threads of the fittings if the nuts are removed.

This is a double ferrule system. The most common installation problem encountered with SEA FROST is the incorrect assembly of the fittings. Assemble all fittings as shown in figure #1.

Note: Loosen the nut slightly before assembly, and then retighten with your fingers before tightening with a wrench. This avoids cross threading.



Figure # 1 Swagelok Fitting Assembly

Swagelok Installation Instructions

1. Always leave two inches of straight, undistorted copper tube leading to all Swagelok fittings to allow proper connection. Measure the tubing the correct distance from the end and mark with a pencil. Refer to Table #1.

Table # 1 Scribe Line Measurements

Copper Tubing Diameter (Inches)	Measurement from the end of the Tubing (Inches)
3/8	11/16
5/16	5/8
1/4	9/16

2. Insert the marked copper tubing, into the Swagelok tube fitting body. See figure #2. The tubing should rest firmly on the shoulder of the fitting body so that the pencil mark is flush with the nut. This mark will also show that the tube has not moved before tightening. As you tighten the fitting, the space from the pencil mark to the shoulder increases. Tighten the nut with your fingers.



Figure # 2 Insert Tube into Fitting Body

3. Scribe the nut at the six O'clock position. See figure 3.

4. Tighten the nut wrench snug. Wrench snug is the first point in the assembly tightening when the tube cannot be pulled from the fitting, (when the ferrules tighten enough to contact the tubing).
5. Hold the fitting body with a back-up wrench and tighten the nut one-and-one-quarter turns (1¼") from the scribe mark.



Figure # 3 Scribe Fitting at Six O'clock



Tighten Swagelok fittings to a torque spec, not infinite tightness. Be sure your starting point is wrench snug. A distorted tube will give a false starting point.

Figure # 4 Turn the Nut 1 ¼ Turns

Note: Make all connections with two wrenches, do not allow the fittings to turn or twist when tightening.

RECONNECTING PRE-SWAGED FITTINGS

You can disassemble and retighten Swagelok tube fittings many times.

1. Insert the tubing with pre-swaged ferrules into the fitting body until the front ferrule seats.
2. Tighten the nut by hand.
3. Tighten slightly with a wrench (approximately one-quarter turn).

HOSE TO COMPRESSOR FITTINGS

Remove the plastic caps and rubber plugs from compressor ports.

To install a tube "O" ring fitting on the compressor, inspect the hose ends to be sure they are clean and free from burrs. Apply a drop of oil to the backside of the nut. This will lubricate the nut to allow proper tightening. Install the proper "O" ring on the hose fitting. Uncap the compressor port, removing the nylon cap and rubber insert plug. Insert the correct fitting in the compressor port. Tighten the nut wrench snug. Using a back up wrench on the compressor port, tighten one quarter of a turn more. This fitting should feel tighter than a SWAGELOK. The elbow will not move when tightening is complete.

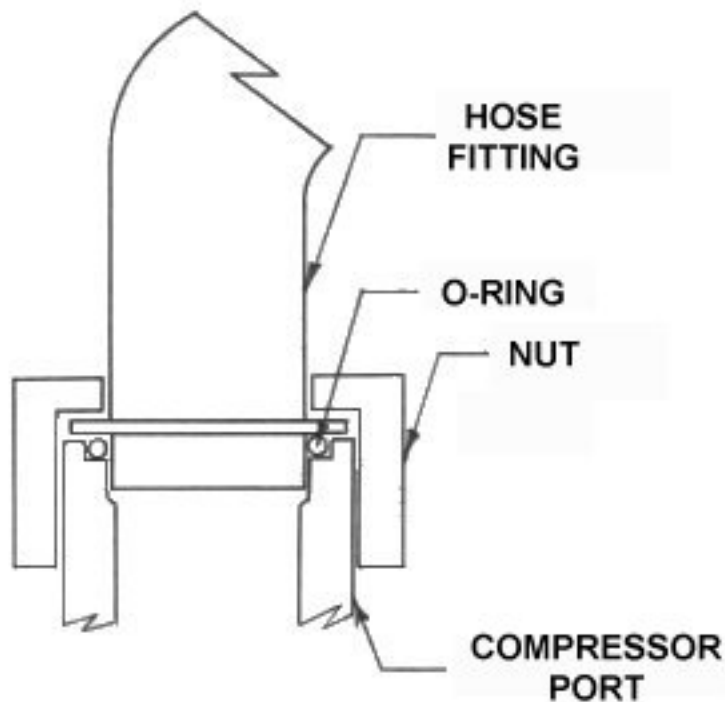

RUNNING THE LINES

- 1) The hose assemblies connecting the compressor to the copper tubing allow for movement of the compressor after installation to enable work on and around the engine without having to disconnect the system. Leave some slack in the hoses and have both hoses directed the same way to allow compressor movement as necessary for access to anticipated repair areas.
- 2) Keep tube runs as short as possible. The suction (return) line should be as direct as possible with a minimum number of bends.
- 3) Helpful tools.
 - Coil spring-type tube benders are available for 3/8"-1/2" O.D. tube. These springs are slid over the tube. The bend is formed in the spring, then the spring is removed by unscrewing.
 - Ford wrench: Jaws at right angle to the handle for hard to access connections.
 - Mini tube cutter: "IMP" by Gould Imperial requires less than 1 1/2" radius clearance for the cut. This is essential to trim the block or plate tubing.

LINE CONNECTION PLAN

The smaller elbow fitting on the hose attaches to the discharge side of the compressor. The other end of the hose has a 3/8" Swagelok fitting. A 3/8" tube goes from the hose to the top of the condenser. From the bottom of the condenser, 3/8" tube runs to the RFD. From the RFD, 1/4" tube goes to V/U on the evaporator. The return line from the V/U 1/2" tube returns to the Swagelok-to-hose fitting. The compressor hose then returns to the compressor.

INSULATING THE LINES

Insulating should be the last step after leak-testing because it will cover fittings that must be leak-checked. On long uninterrupted lengths of tubing, however, the insulation can be slipped over the tube early. Insulation should be installed only on dry lines.

The suction return line is cold and will attract moisture (as frost) when running. The suction return line includes all the exposed 1/2" tubing and the larger fittings.

Install the insulation in a manner that will not trap water around a low point. Trapping water in the insulation will reduce the operating life of tubing and fittings. If the insulation is split and wrapped over the tube, install it with the split side down.

Tubing within the icebox need not be insulated.

Insulation is provided to insert the tube into, or to split and wrap onto the tubes that are impossible to feed into the insulation. The foam wrap should be taped with vinyl electrician's tape.

Tie wraps should be used to support the wiring, tubing, and insulation.

DISPLACING OIL IN NEWLY INSTALLED COMPRESSOR

The compressor is shipped with the proper amount of oil for the system. **The oil must be displaced from the cylinders before the compressor may be turned by the boat's engine.** After completing all the connections, turn the outer face of the compressor drive disk for at least five turns by hand.

ASSEMBLY INSPECTION CHECK LIST

- [] 1. Check the lines to be sure they are properly routed. Follow "Running the lines" text. Check to see that the compressor discharge connects to the top of the condenser and the water line enters the bottom and leaves the top.

- [] 2. Check that the RFD sight glass can be seen.
- [] 3. Check **all** the connections with wrenches to be sure they have been made up. (Refresh your knowledge by re-reading the Swagelok instructions.)
- [] 4. Check the belt and compressor bolts for tightness.
- [] 5. Check to make sure the compressor is mounted in an upright position.
- [] 6. Check the panel wiring by switching on the blowers. The compressor clutch should click.
- [] 7. Check the neatness of the installation; sufficient service access; secure wiring; tubing and hoses supported to prevent damage and chafing.
- [] 8. Check the service access. The service access ports must allow attachment of the connecting valves.
- [] 9. Check (after leak checking and testing) that the system is properly insulated. See; "Insulating The Lines".

REFRIGERANT HANDLING AND SAFETY

Do not proceed with any aspect of a procedure if you do not fully understand the procedure and know what results to expect. Understand fully that pressure exists in refrigeration systems. Be careful.

SEA FROST is charged with Refrigerant 134a. Refrigerant 134a is a chemical compound called tetrafluoroethane. It is almost odorless. It's boiling point is -15. degrees F. at sea level. It is heavier than air. It's label and container color is cloud blue.

GENERAL SAFETY THIS IS IMPORTANT. READ THIS!

R-134a is safe if handled properly. Avoid breathing vapors and prolonged skin exposure. Avoid using in areas of open flames. The vapor is heavier than air and may reduce oxygen available for breathing. Use with sufficient ventilation to keep exposure below recommended limits. **Do not mix with air for leak testing or use with air for any purpose above atmospheric pressure.** Liquid R-134a will freeze skin. It's especially dangerous to the irreparable tissues of the eyes.



WEAR EYE PROTECTION

Do not pressurize an empty system with R-134a without first evacuating the system with a vacuum pump.

Never operate a system with the high side (discharge) open to the refrigerant supply. Pressurization of the refrigerant container could cause it to burst.

When charging or working on the system with the engine running, watch for moving belts and pulleys. Loose clothing and long hair can pull you into a belt.

Do not connect or disconnect gauges to a system while the compressor is operating.

PROCEDURES FOR WORKING WITH R-134a

- 1) A new uncharged system must be evacuated before adding R-134a.
- 2) An R-134a system must only be pressurized with R-134a or nitrogen.
- 3) Only service tools dedicated to R-134a are to be used. No parts, tubing, fittings, receivers, driers, service gauges, or any refrigerant carrying components may be fitted to a R-134a system from a used system or from a CFC based system. Damage caused by the use of parts not supplied by Sea Frost for a R-134a system will cancel all claims against Sea Frost.
- 4) No oil is to be added to the engine drive system but the PAG oil supplied by Sea Frost, labeled and capped for engine drive use. No oil is to be added to a system with out prior consultation with Sea Frost.
- 5) The oils used in R-134a systems are extremely moisture sensitive (hygroscopic). Do not leave any tube end or component connection open to air while assembling the system. Be sure to use only new capped copper tubing and be sure to cap the copper coil after cutting it.

ACCESS TO THE SYSTEM: SERVICE ACCESS PORTS

The access ports are two small capped valves on the hose ends. These ports are the service access to the system and are of different sizes. To access these ports the proper connecting valve must be used.

Be sure the plastic port caps are installed tightly after charging or service. The caps are to seal the ports. Without the caps the ports may leak.

Note: This system is charged with r-134a; it must be charged with r-134a only. Use only dedicated r-134a gauges and equipment. Any contamination from CFC based refrigerants will destroy this system.

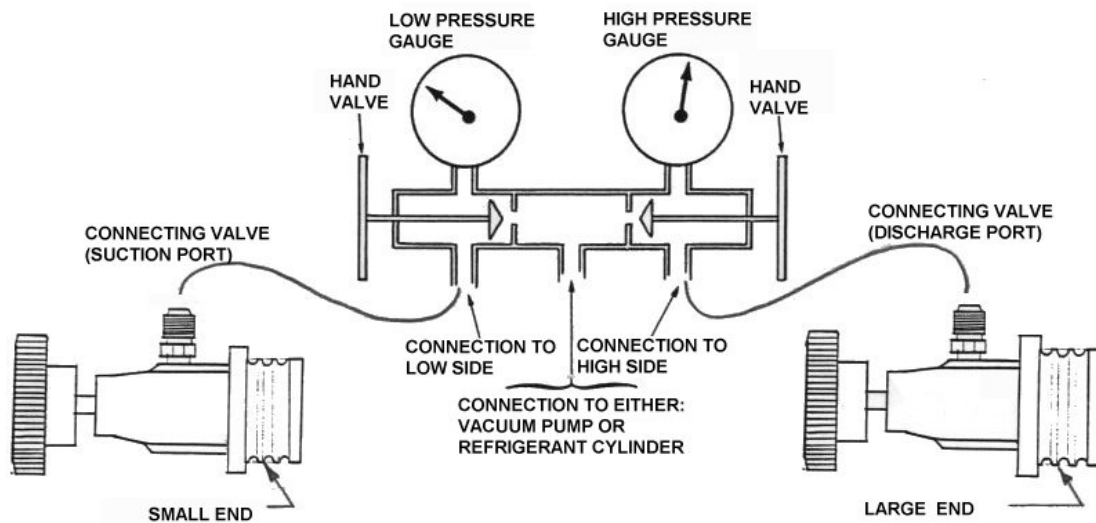

GAUGES

Gauges must be used in the evacuation and charging. They will provide information on the operation of the system when troubleshooting.

A gauge sets consist of two gauges installed in a manifold with two hand wheel valves and hoses to connect the gauges to the system. The left gauge (blue) is a compound device; it indicates pressure and also vacuum. The right gauge (red) indicates pressure only. The hand wheels open a center port (yellow) to the left or right side respectively. Operation of the hand wheels is only necessary when moving refrigerant or evacuating. With the hand wheels closed, the gauges read the pressures of the connection points. At the end of the red and blue service hoses are R-134a connecting valves

R-134a SERVICE CONNECTING VALVES

The R-134a connecting valves on the gauge hose ends are quick connect fittings with a specially designed valve that when turned opens and closes the hose end while opening the access service port.

CONNECTING GAUGES TO AN UNCHARGED SYSTEM

To connect these fittings to the access service ports, remove the protective sealing caps from the ports. Note that the ports are of different sizes. The larger diameter port is the discharge side and the smaller port is the suction side. Pull back the collar on the connecting valve and push it over the appropriate access port. Turn the connecting valve clockwise to open. During the service operation, these valves are left open.

Control of refrigerant and vacuum is by the manifold hand wheels.

To install gauges on a charged system, with the system off, attach the connecting valves to the access service ports. Proceed to "Venting the Gauge Set".

VENTING THE GAUGE SET

If the gauge set is not fitted with sealing valves or has not been purged with refrigerant, vent the hoses at the manifold body by opening the hand wheels to an open center hose for a few seconds allowing some of the system refrigerant to purge the hoses of air.

DISCONNECTING GAUGES

Disconnecting the gauge set after running the system may be done by turning off the discharge connecting valve first. Remove the connecting valve and re-cap the service access port. Turn off the refrigerant supply or blank off the center hose. Both hand wheels on the gauge set may be opened and the compressor operated to extract the refrigerant from the gauges. When the pressure in both gauges drops to the low side operating pressure turn off the hand wheels and the connecting valve. Turn off the compressor. Remove the remaining connecting valve and re-cap the access port.

Disconnecting the gauge set on a static system may be done by turning off the connecting valves and disconnecting them from the access ports. Recap the access ports.

Adding charge to a working system should be done through the suction side (blue). (See; "Safety".) The center hose is connected to the can tap. Be sure to vent the hoses to displace any air that might be in them. (See; "Venting the Charge Hose".) Keep your gauges clean. Inspect the rubber gaskets and "o" rings on the hose ends. Leak-check the gauge valve packing and all hose connections. Check and reset the "O" on the low side gauge to atmospheric pressure, if necessary.

VENTING THE CHARGE HOSE

To avoid pulling air or other contaminants into the system, it is necessary to vent the air from the hose that is used to carry R-134a to the system. To vent the hose, open the can tap valve with the can upright (vapor) then loosen the center hose fitting at the manifold. After several seconds of venting tighten the hose end fitting.

TAPPING A CAN OF REFRIGERANT

Be sure the can of R-134a is clean and dry. Any contaminants on the top of the can or in the hose will enter the system. First, install the clamp assembly on the top of the can. Next, screw the valve wheel into the valve body, closing the valve. (The metal point will protrude from the gasket, but it will make its own seal while piercing the can. Be certain that the gasket is present and is smooth and elastic.) Now, with the can upright, screw the valve body assembly into the clamp on the can, turning until the point pierces the can and the rubber gasket has sealed. The can is now tapped.

LIQUID OR VAPOR

REFRIGERANT IS EITHER a vapor or liquid. To supply vapor to a system, keep the refrigerant can in the upright position. To supply liquid to the system, invert the can, valve down. Be sure the can is handled carefully to ensure the correct refrigerant condition is supplied.

CHANGING CANS

Close the valve on the empty can. Unscrew the can from the valve body. Some pressure may be present. Let this drop before completely removing the can tap. Switch the clamp to the other can, and rethread onto the valve body. The compressor (switch panel) should be turned off while changing cans.

COMMISSIONING PROCEDURE

EVACUATION WITH A VACUUM PUMP

Evacuation removes air, readying the system for charging.

Connect a gauge set to the access ports (See "Access to the System and Gauges").

Connect the gauge center hose to a high vacuum pump. Start the pump and slowly open the suction gauge hand wheel. As the vacuum drops below 20 inches, open both hand wheels fully.

EVACUATION LEAK TEST

Evacuate the system to the best vacuum (lowest pressure). Close the hand wheels to the pump. Observe the vacuum gauge and be sure the pressure remains constant for 5 minutes. If the pressure rises rapidly, check all the connections again. Re evacuate to the lowest pressure and test by holding a vacuum with the gauges closed. Be sure the system holds this vacuum. Proceed by opening the hand wheels and continuing the evacuation process for 20 minutes or more.

INTRODUCING INITIAL CHARGE

After the leak checking and pump down, shut off the hand wheels, disconnect the center hose from the pump and connect it to the refrigerant supply. Vent the hose from can tap (refrigerant supply) to the gauge body (See; "Venting the Charge Hose"). With the refrigerant can (12 oz) in the inverted (liquid) position, open the discharge hand wheel valve and feed in about 1/2 of a can of refrigerant (6 to 8 ounces). Close the valve and begin an inspection of all the connections in the system. Proceed to leak checking.

LEAK CHECKING

Leak checking is a very important step, which should be done with diligence. A leak will cripple this system. Please take the time needed to be sure all connections are tight. Check every connection even the ones that were pre-made in manufacture.

The "Evacuation Leak Check" is a preliminary check and is not to be considered a system leak check.

LEAK CHECKING A CHARGED SYSTEM

ABOUT PRESSURES

Refrigerant in a saturated condition, part liquid and part vapor, will exert a pressure that is a function of its temperature. The higher the temperature, the higher the pressure will be. Avoid leak checking in cold weather.

A refrigerant leak will show with moderate pressure. A leak is not a function of pressure. Pressure is only required to aid in detection.

In cold weather, it is possible to raise the pressure in the system by warming the plate with a light bulb left in close proximity to the plate for several hours.

There are two ways to leak-check a pressurized system:

1. **Leak check with soap bubbles.** To check with bubbles, use a solution of dish soap and water. Soap each connection and observe all sides of the connection with a strong light and a mirror. A leak will blow bubbles. Without careful examination and plenty of pressure, this test is not reliable.

2. **Leak check with a R-134a electronic leak detector.** To check with an electronic detector, use a detector designed for R-134a. Slowly trace the area with the probe. Refrigerant is heavier than air, therefore, trace below the fitting. Most units can be calibrated to home in on a leak. See detector instructions. We use and recommend

electronic detection. Be sure to test the operation of the detector before and after you leak check the system

IF A LEAK IS DETECTED

Try tightening the fitting nut slightly. If the leak is not stopped, it is possible that the fitting was incorrectly assembled. Discharge the system, then disconnect the fitting for inspection. After reassembly, proceed to the leak check procedure.

Be aware that propellants and solvents in sprays and foams may upset electronic detectors.

- To confirm a leak detected with a detector use bubbles and be sure it is a leak and not some erroneous vapor that is upsetting the machine.
- Electronic detectors do not function below 40.F.
- A good leak detector is able to pick up leaks as low as 1/2 oz per year.

NEW SYSTEM CHARGING

1. To commission a new system, do a thorough leak check. Open the discharge hand wheel valve with the can inverted to introduce more refrigerant. The system is designed for 24 ounces or two cans of refrigerant. Shake the can to determine the amount remaining. If one can is accepted change cans. Refer to "Changing Cans". Install as much of the total charge as possible by this method. Close the discharge hand wheel.

2. Turn the compressor drive disk several times by hand. This displaces oil in the newly installed compressor.

3. Operate the engine at 1000 to 1200 rpm, and turn on the compressor.

4. The sight glass will show a stream of foam, indicating a partial charge. Install the balance of the total charge by opening the suction hand wheel with the refrigerant supply in the vapor position. The new system charge should be 24 ounces.

5. When the sight glass clears, top off with approximately 4 oz of refrigerant, subject to the formula in "proper charge amount: maximum charge."

6. On a new system, turn off the compressor for several minutes after charging, and then restart it. Run the engine at slow speed (under 1200 rpm) with several on/off compressor operations. Allow 2 minute "off" periods between 2 to 15 minutes operating periods. This distributes the oil. When charging is complete, stop the compressor and allow the entire system to equalize and for the fittings to dry, an hour in most conditions.

7. When you have completed the observation and testing, close the gauge connecting valves and disconnect them from the system. Recap the access ports.

8. Recheck all the connection points for leaks.

9. Spray the acrylic coating, or similar rust inhibitor, on all the fittings and components when they are dry.

READING THE SIGHT GLASS

A clear sight glass when the compressor is operating signifies a sufficiently charged SEA FROST Engine Drive System. To determine the meaning of "clear", notice the appearance of the RFD sight glass when the system is at rest with the compressor off. This is a "clear" glass.

Warning, a clear sight glass can also indicate a completely empty system. Anytime the compressor is started, white foam should appear in the sight glass indicating that refrigerant is present. This foam may disappear quite quickly. If no foam is evident and the system is not cooling, the system is empty. Do not operate the system in this empty condition. Operation in this mode will ruin the compressor. Turn off the main breaker to the Control Panel or remove the compressor drive belt to prevent operation until system can be properly leak tested and recharged.

Fast moving white foam with the compressor operating indicates an insufficient charge level. Watch closely for a transition from foam to total liquid, indicated by a clear sight glass. This transition point can be missed if proper attention is not given. In addition, it is possible for the sight glass to show large bubbles even when the charge is sufficient, so it is important to differentiate between "foam" and "bubbles". The foam condition has velocity and direction; the bubbles are large, temporary, and nearly stationary. Do not try to chase away these larger bubbles with more refrigerant: overcharging will then occur. Air in the system may give a false sight glass reading, which could lead to overcharging. If in doubt, discharge a suspected overcharged system to continuous foam and slowly add refrigerant to clear the glass. Monitor the sight glass continually since the glass will not indicate when the system is overcharged.

In a warm system, when the plate is above freezing (32.F) upon start-up, the sight glass may take several minutes to clear. A cold system, in cold water, may show a clear glass within seconds of start-up.

RFD SIGHT GLASS DETAIL

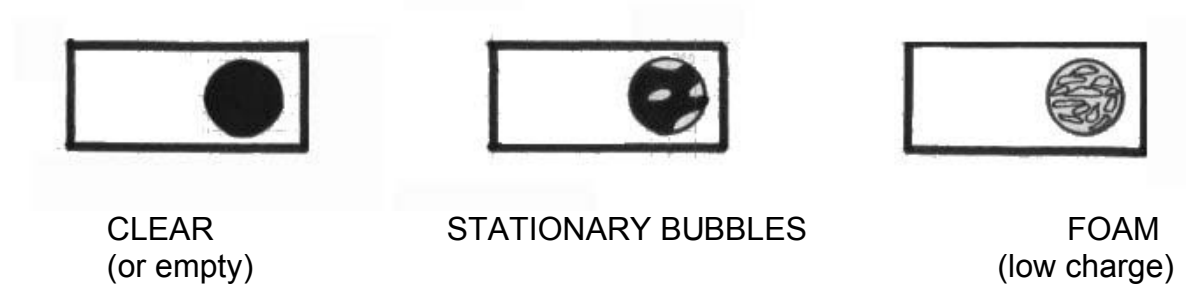

PROPER CHARGE AMOUNT

The engine drive system is designed to hold 24 ounces of refrigerant. This is equal to two cans of R-134a, supplied with the system. This is the maximum charge. The sight glass must clear by the time the return line (suction/large diameter hose) goes below 32 degrees F.

GENERAL INFORMATION

Operating pressures will vary with rpm, water temperature, and water flow. Generally, the discharge pressure will peak when the unit first starts. Increasing pressure indicates an overcharge or no water flow. The suction pressure will drop to the 20's rapidly. Suction pressure will drop more rapidly when the seawater is cold. A deep vacuum indicates the V/U is frozen or plugged. Failure to "pull down" indicates the V/U is malfunctioning or flooding. The compressor case will feel warm.

The V/U has been operated prior to shipment. There are no field superheat adjustments.

We do not recommend charging sea frost gear with bulk cylinders since it is hard to determine how much refrigerant has been installed. The feed pressure with a bulk cylinder can be higher which may cause skipping through the condenser, causing bubbles in the sight glass. However, if bulk cylinders are used, keep the suction feed pressure below 30 psi and add vapor only.

R-134a will become cloudy and indicate similar foaming in the sight glass as the pressure on the discharge side of the systems becomes too great. Adding charge to clear this condition will damage the compressor.

LOW PRESSURE CUT-OUT

A low-pressure cutout is fitted to prevent freeze up of the air handler. It is adjustable. It should be set to about 22 to 25 PSIG. If the unit is low on refrigerant, the low-pressure

cutout will cycle the compressor. If the unit is empty the low pressure cut out will disconnect the compressor until refrigerant is added and the pressure rises.

CHECKING THE REFRIGERANT CHARGE

Checking the refrigerant charge must be incorporated into a routine maintenance schedule.

- 1) Locate the receiver filter drier (RFD). The location of this part varies from boat to boat, but it is often found in the engine compartment, in a locker, or beneath the cabin sole. It is a blue metal can about 9 inches high and 3 inches in diameter, with brass fittings connecting it to copper tubing. If you do not locate the RFD quickly, follow the route of tubing from the engine compartment to the air handler. Along the route, you will find the RFD along with other SEA FROST components). The RFD has a sight glass for viewing the flow of the refrigerant.
- 2) Start the boat's engine. Check to be sure that the engine is pumping water.
- 3) Locate the SEA FROST Control Panel. With the engine running at a fast idle (900 to 1200 rpm), while looking into the sight glass in the RFD, have a helper start the compressor. The engine should load. An empty system will put very little load on the engine.
- 4) Monitor the sight glass continually. If the sight glass does not show the presence of refrigerant within a minute of operation, the system is empty. Turn off the compressor and follow the procedure in the troubleshooting section.
- 5) If the white foam is present, watch closely for the transition to clear. If the glass indicates insufficient charge level, additional charge will be needed. Turn off the compressor. Attach a can of R-134a with a properly vented charge hose to the suction access port. Monitoring the sight glass continually, start the compressor and slowly add refrigerant vapor until the glass clears. Top off with about 4 ounces.
- 6) Feel discharge air after starting the compressor. If the sight glass clears, yet the air temperature does not drop after 2 minutes of operation, stop the compressor and follow the procedure in troubleshooting.

DISCHARGING THE SYSTEM

Follow all state and local regulations for handling refrigerants.

Before the connections or components can be disassembled, the refrigerant must be discharged. Connect a gauge set to the suction access port. Slowly reclaim the refrigerant into an approved reclaiming system, keeping the pressure under 20-psi. Do

not loosen any connections until the system shows "0" pressure.

Discharge an overcharged system at the same 20-psi rate for a minute at a time. Be sure the gauge hand wheel is off before starting the compressor.

TROUBLESHOOTING

The most common problems that can occur in a SEA FROST Engine Drive System are:

1. Loss of refrigerant charge resulting from leaks.
2. Moisture or dirt plugging the valve.
3. Compressor malfunction due to loss of refrigerant charge.
4. Overcharge switch cycling.

STEP 1

Gather information as to the nature of the problem before operating the system. A leak often leaves a trace of oil. Inspect fittings, hoses, and tubing for wear, corrosion, and chafe. Do not operate the compressor until the trouble is corrected.

Overcharge switch cycling is indicated by the compressor turning off when starting a warm system, or if the cooling water is not flowing. Determine the condition by checking the water flow from the discharge through hull. If the water flow is not at fault discharge some refrigerant. The compressor should not be operated during discharging. This is a trial and error procedure until the compressor stays on without cycling. Check the sight glass for proper charge. Be sure the sight glass still clears. For further troubleshooting, attach purged gauges to access ports or observe the temperature of the lines.

- ❖ If the ambient temperature is warm and pressure readings are below 50 psi with the compressor off (in 50 degree F or higher ambient conditions), pressurize the system with R-134a and leak-check.
- ❖ If the pressure readings are over 50 psi with the compressor off, proceed to check charge level via sight glass and charge if needed. Charge loss indicates a leak that must be corrected.

STEP 2

If the system continues to operate improperly after Step 1, check for moisture or dirt plugging the valve. Run the system, observing closely the gauge readings and discharge air temperature, noting the following.

- ❖ If system is warm upon start-up, a DIRT-PLUGGED Valve will show an immediate

deep vacuum reading on suction side. Consult SEA FROST for cleaning techniques.

❖ A MOISTURE-PLUGGED VALVE is indicated by a deep vacuum reading on the suction side after 1 to 5 minutes of operation from warm, FOLLOWED BY any combination of these symptoms:

❖ The temperature at the compressor discharge fitting and the copper tube at the top of the condenser drops from hot to warm.

❖ The temperature of the suction line from the V/U increases.

❖ Moisture enters either through suction side leaks or during initial installation. The moisture will freeze at the V/U, reducing or eliminating cooling activity. Turning off the system and allow the V/U to warm to above freezing. Restarting may temporarily solve the problem. If not, change the RFD as follows.

STEP 3

To change a saturated RFD, allow the system to warm to ambient temperature, thereby preventing moisture from condensing in the system. See "Discharging the System." Before disassembly of any part in this system be sure the charge is completely discharged. With a backup wrench holding the brass body of the Swagelok fittings, loosen and back off the nuts. The tubing may be pulled out of the fittings. Remove the RFD. Replace only with an identical unit. The Sea Frost RFD is a drier and is also a receiver/filter. The desiccant and the oil in the Sea Frost RFD are special to this system and R-134a. Installation of the wrong part or oil will destroy the system.

NOTE: This system contains a measured amount of lubricating oil. Be sure the RFD being installed is a blue SEA FROST Engine Drive RFD that has been oil compensated. Record all component exchanges in the on-board owner's manual.

Follow the "remake" instructions for Swagelok fittings.

To ensure removal of system moisture, use a vacuum pump, and evacuate the system with the highest possible ambient temperature.

Recharge. Refer to "New System Charging".

MOISTURE IS A SYMPTOM. If moisture becomes a problem, carefully leak check the low side of the system. Moisture leaks in!

Sea Frost
372 Route 4
Barrington, NH 03825

(603) 868-5720
(800) 435-6708

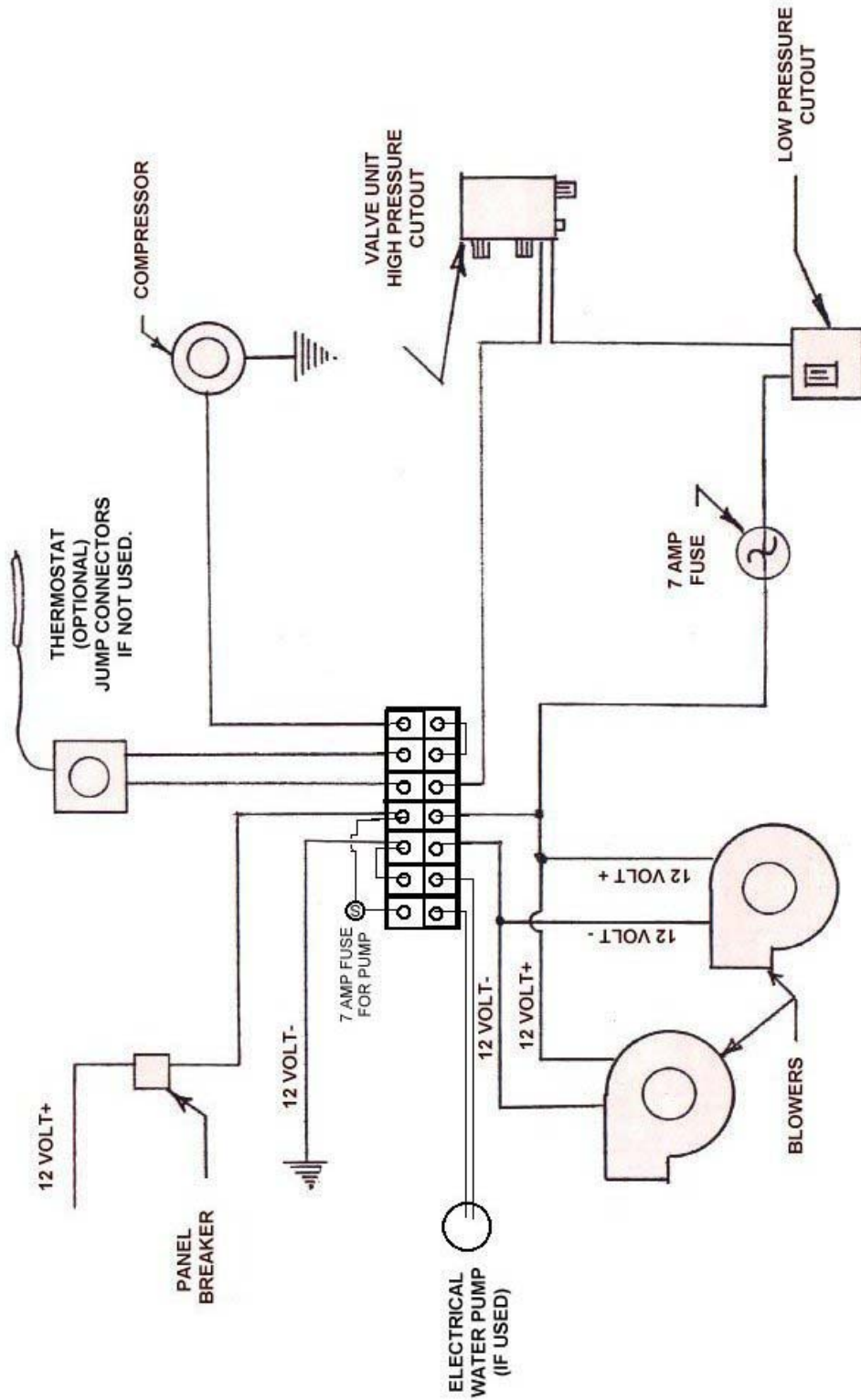

SEA FROST
ENGINE DRIVE AIR CONDITIONER
12 VOLT WIRING

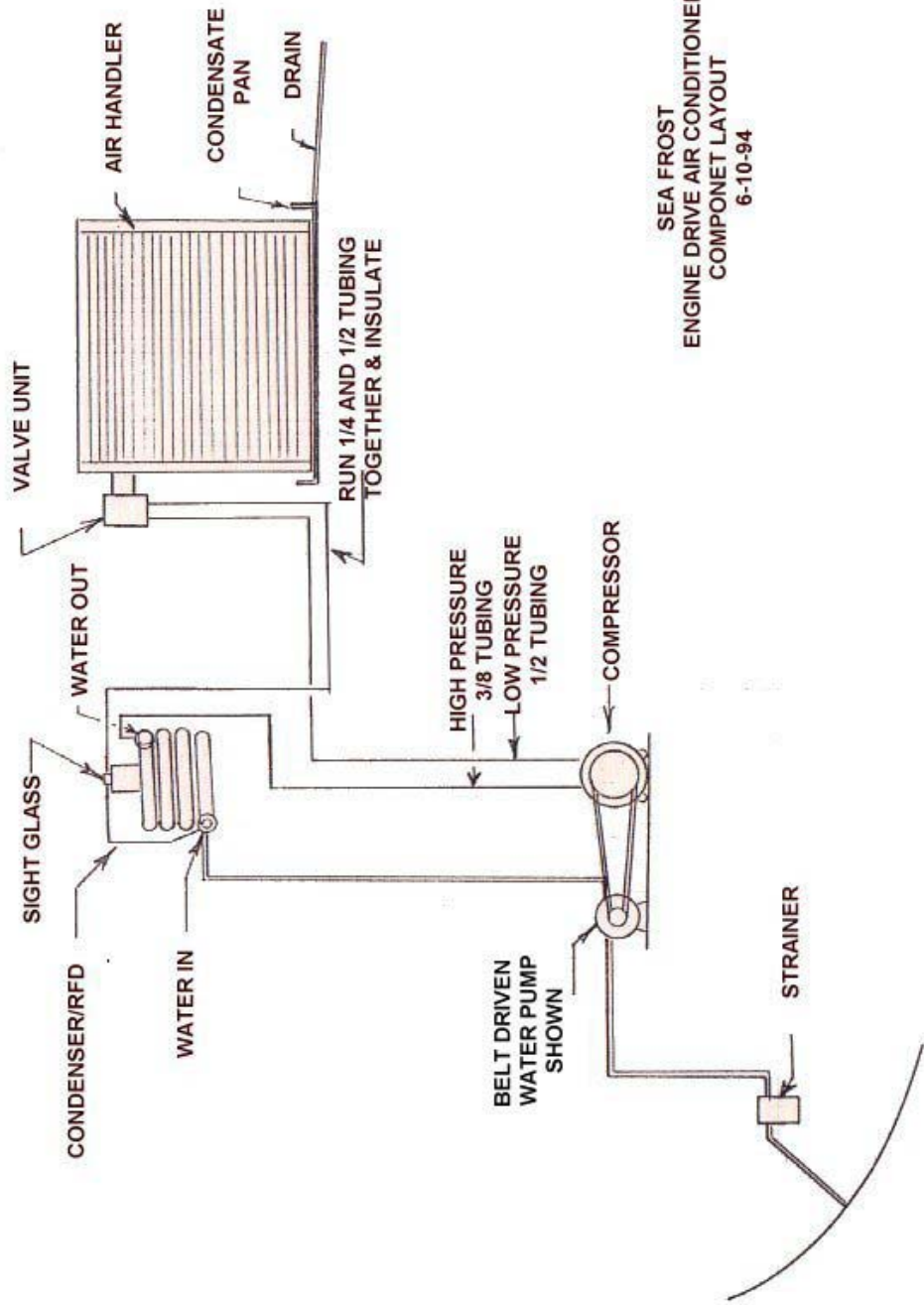

SEA FROST
ENGINE DRIVE AIR CONDITIONER
COMPONENT LAYOUT
6-10-94