

SEA FROST BD 12 OR 24 VOLT D.C. SYSTEM With Water Cooling Option

CONDENSING UNIT LOCATION AND MOUNTING

The water-cooling option should be considered supplemental cooling. Installation should proceed with a proper air-cooled installation first. The water-cooling feature should be used to enhance efficiency on occasions when cold-water temperatures are encountered or interior cabin air temperatures are extreme.

The design of the Sea Frost BD allows placement in an enclosed space such as a cabin locker or sail locker. Intake air should be drawn in from the cabin area to insure the coolest, driest air supply. Standard 4" duct hose may be used. Discharge may need to be vented to allow warm air to escape. Intake ducting from the exterior of the boat may cause damp salt air to be drawn in which might reduce the life of your BD. This will also increase below deck moisture. **ALLOW 1.5" CLEARANCE BETWEEN THE CONDENSER (BACK VENT AREA) AND ANY BULKHEAD TO INSURE PROPER AIRFLOW THROUGH THE CONDENSER.**

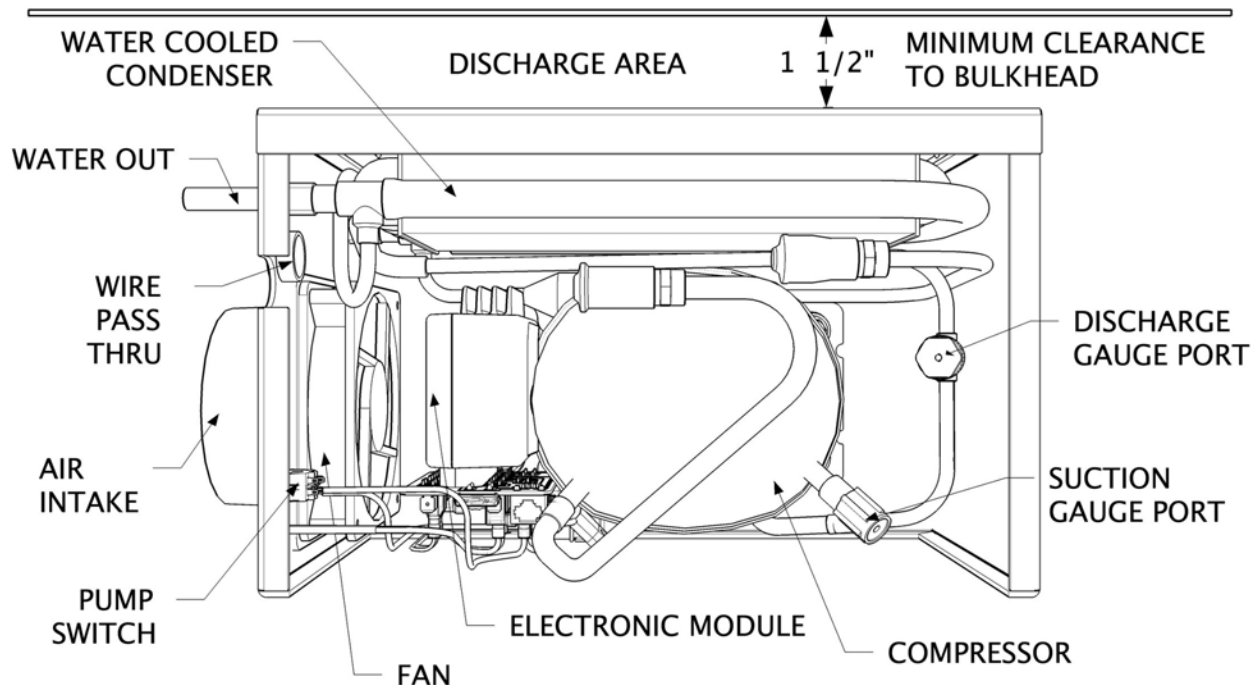

Service access and installation requires that the front, left end (inlet) and back (condenser) air outlet be exposed. A duct hose will require 4 inches of clearance past the end of the cabinet.

Mount the Sea Frost BD level, (the compressor is at the bottom). The BD may be platform mounted. Two holes have been drilled through the bottom for screw mounting to a shelf or bulkhead. If using the bulkhead mount bracket kit, follow directions supplied with the kit.

INSTALLATION REQUIREMENTS FOR CONDENSING UNIT

- Never block air inlet or outlet.
- Provide for driest, coolest air for intake.
- Total air duct length for intake should not exceed six feet.
- Make sure installation location is vented to allow warm discharge to escape.
- For intake through a finished panel, order black flange grill.

PUMP INSTALLATION

For proper operation, please understand pump installation before beginning. The BD water-cooled uses a magnetically coupled centrifugal pump. It is not self-priming and must be well below the water line. Air pockets caused by loops or descending lines from one component to the other may cause pump problems. This pump must never be run dry. It is water cooled and lubricated. The wet end may be destroyed if it is started dry. Using a different pump will defeat any energy gain.

A separate through hull fitting 1/2" or larger should be used. It should be as low in the boat as possible and away from head and cockpit drains. A forward facing scoop will prevent problems if the unit is operating underway.

A large seawater strainer should be mounted above the seacock.

The pump should be mounted horizontally. It should be higher than the strainer. The discharge should be on the top. A 3/8" hose should feed up hill to the BD unit. This should connect to the lower water fitting. From the upper water fitting a 3/8" hose should connect to a through hull above the water line.

Refer to the pump installation drawing at the end of this manual.

PUMP WIRING

Connect the red pump wire to the terminal screw marked pump (+) and the black one to (-) under the compressor housing cover. Be sure the toggle switch is off until the boat is launched and the pump is wet.

MOUNTING THE EVAPORATOR PLATE

The plate should be mounted in the cabinet as high as possible to take advantage of thermal convection. It may be used as a shelf, mounted on the ceiling or any wall. There is no restriction as to position. Standard aluminum ice trays may be used for ice making if the plate is used as a shelf. If the plate is wall mounted a vertical ice tray kit is available. Before mounting the plate, consider access to the thermostat.

The Sea Frost BD plate mounts with a Wellnut expandable neoprene blind hole fastener. A template or the plate itself should be used to locate the mounting holes. Drill a 3/16" pilot hole. Increase this hole to 3/8".

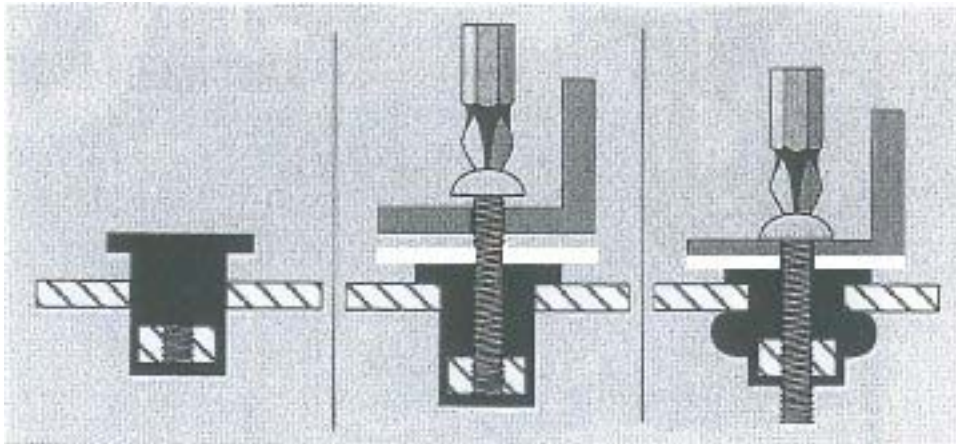

1. Place Well-nut insert all the way into Pre-drilled hole until flange is firmly against mounting surface.	2. Pass Machine screw through part to be fastened and the white spacer washer.	3. Tighten until snug.
---	--	------------------------

INSTALLING REFRIGERANT LINES

Two copper lines connect the stainless steel evaporator plate and the compressor. One is 5/16" and the other is 1/8".

Run the lines behind any and all serviceable parts. Avoid heated engine spaces. Do not coil excess tubing in an engine space. Protect the lines from being crushed, snagged or stepped on.

The quick connect fittings require a 1 inch diameter clearance hole and are staggered to allow passing through a bulkhead or insulated wall. Keep the plastic cap and shrink wrap protective cover in place until the connections are made.

WORK CAREFULLY WITH THE COPPER TUBES TO AVOID PINCHING OR KINKING THE TUBES. ALL BENDS SHOULD BE SMOOTH WITH NO LESS THAN A 2" RADIUS.

Support the tubing every 18 inches as necessary using tie wraps fastened with self-tapping screws. Insulate at least 3' of the line set as it exits the refrigerator box. Seal both sides of the exit holes in the refrigerator box with permagum sealing compound.

WARNING:

The Sea Frost BD system is shipped pre-charged with refrigerant. This refrigerant is under some pressure. Do not fiddle with the connectors or the service ports. You might get hurt! Wear safety glasses when connecting the compressor fittings.

COMPRESSOR CONNECTIONS

The connections in the BD system are self-sealing when connecting and disconnecting. It is very important to inspect (and clean if necessary) the surfaces and "o" ring seals before assembly. If dirt, moisture, or grit, is on these connectors the system may be contaminated or the seal may be ruined.

Working with one line at a time, remove the heat shrink material and the plastic caps. Connect the larger copper line to the compressor fitting. Connect the small copper line to the remaining fitting.

Use two wrenches to tighten the fittings wrench snug. **DO NOT OVER TIGHTEN!**

ELECTRICAL CONNECTION

Follow ABYC wiring guidelines for proper, safe wiring.

VOLTAGE	12 D.C. or 24 D.C.
AMP/HR DRAW	4.5 TO 6 @ 12 VOLTS PUMP ADDS 1 AMP/HR
PEAK AMP/HR START (12 volt)	14
LOW VOLTAGE CUT OFF	10.4 VOLTS @ 12 VOLTS 22.8 VOLTS @ 24 VOLTS
WIRE SIZE TO BATTERY SUPPLY	AWG # 10 TO 10 FEET AWG # 8 MAXIMUM 25 FEET
FUSE:	15 AMP MAX MUST BE INSTALLED AT BATTERY

WIRE SIZE

12-volt installations use AWG #10 wire for distances up to 10 feet for the wire pair, and #8 AWG wire for distances up to 25 feet for the wire pair. **Fuse 15 Amps.**

24 Volts: The module will self calibrate to the applied voltage and provide proper fan voltage. The remote water pump must be a 24volt pump. **Fuse 7.5 Amps.**

If the polarity is reversed, the electronic module will not work.

In any application, use the next largest wire if in doubt to prevent a voltage drop. A fuse is preferred over a breaker as it has less potential voltage drop.

CONNECTIONS

For best performance, the electronic module must always be connected directly to the battery or battery selector switch. Connecting the module through the boat's breaker panel may cause a voltage drop; small wires and multiple connectors create resistance.

FOR PROTECTION OF THE INSTALLATION, AN EXTERNAL FUSE MUST BE INSTALLED CLOSE TO THE BATTERY IN THE POWER SUPPLY (+) CABLE.

The fuse is not provided. Connect a red wire from 12 or 24 volts positive to the (+) terminal of the **line in** terminal strip. Connect a black wire from 12 or 24 volts negative to the (-) terminal of the **line in** terminal strip.

Do not operate the BD directly from a DC charger without a battery. Never apply power to any of the other terminals.

REFRIGERANT CHARGE

**This system operates with refrigerant R-134a and is pre charged.
The proper charge amount is 5-6 oz.**

An automatic expansion valve regulates the evaporator pressure. This valve is factory adjusted to maintain a constant evaporator pressure of 0 to 2 psi. Do not remove the heat shrink tubing and plastic cap or turn the knob beneath it.

Technicians note: Charge amount will not affect the evaporator pressure.

STANDARD THERMOSTAT WIRING CONNECTIONS

Connect the thermostat wires to the T and C terminal rows using the far right side connections. The PCB contains a 1500-ohm resistor, which programs the module to operate the compressor at maximum RPM. There is no polarity requirement regarding the thermostat wires. Either one can connect to either C or C.

Standard BD thermostat wires ~ copper and silver.
Remote (snowflake panel) thermostat wires ~ red.
Electronic thermostat thermometer wires ~ green and white or cat 5 data cable with RJ 45 connector. Install a 3-amp ATC fuse in the fuse holder on the Module PCB board. This fuse is required only if using the RJ-45 jack.

STANDARD THERMOSTAT OPERATION

The thermostat is attached to the plate. The wires follow the refrigerant lines to the compressor section. Protect these wires from cuts and chafe.

The BD thermostat is variable. Turning the knob fully counterclockwise turns the unit "OFF". The fully clockwise setting is the coldest. The thermostat may be adjusted to obtain any temperature desired in the cabinet and the thermostat may be calibrated should the warmest setting be too cold.

Built on Thermostat Calibration: This should not be required however adjustment can be made.

To calibrate the thermostat remove the upper and lower screws on the stainless steel thermostat cover. Carefully move the stainless steel thermostat cover to reveal the white plastic cover, which is on the thermostat. Underneath the white plastic cover, locate the calibration screw. To lower box temperature, rotate this screw counter clockwise. One full revolution will change the box temperature approximately 6 degrees F. To raise the temperature in the box rotate the screw clockwise.

OPTIONAL REMOTE THERMOSTAT OPERATION

Slide the bulb clip onto the edge of the plate and over the sensing bulb. The sensing bulb must be in excellent thermal contact with the plate. We recommend that the probe be mounted on the plate in the one of the lower mounting positions as shown in the drawing below. This is best because these positions remain colder.

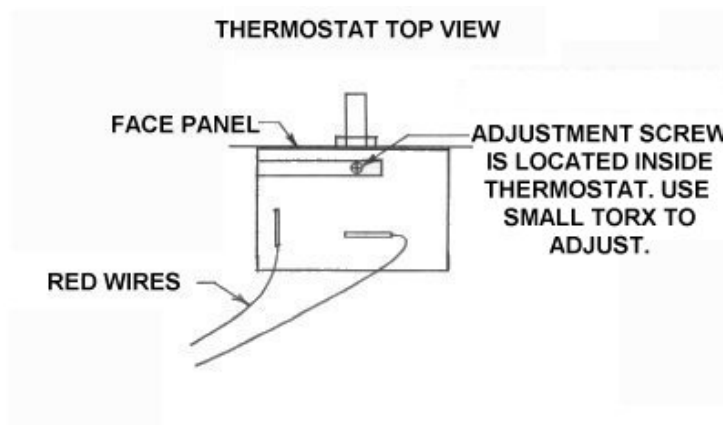
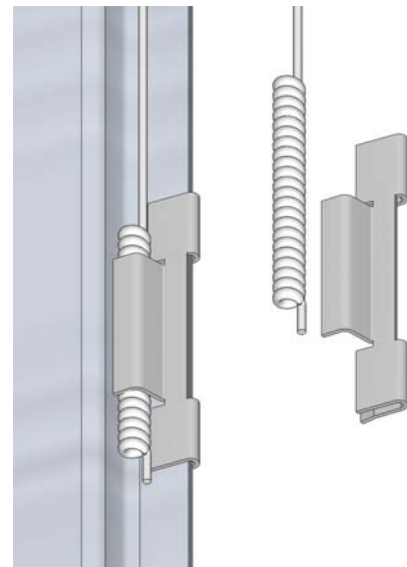

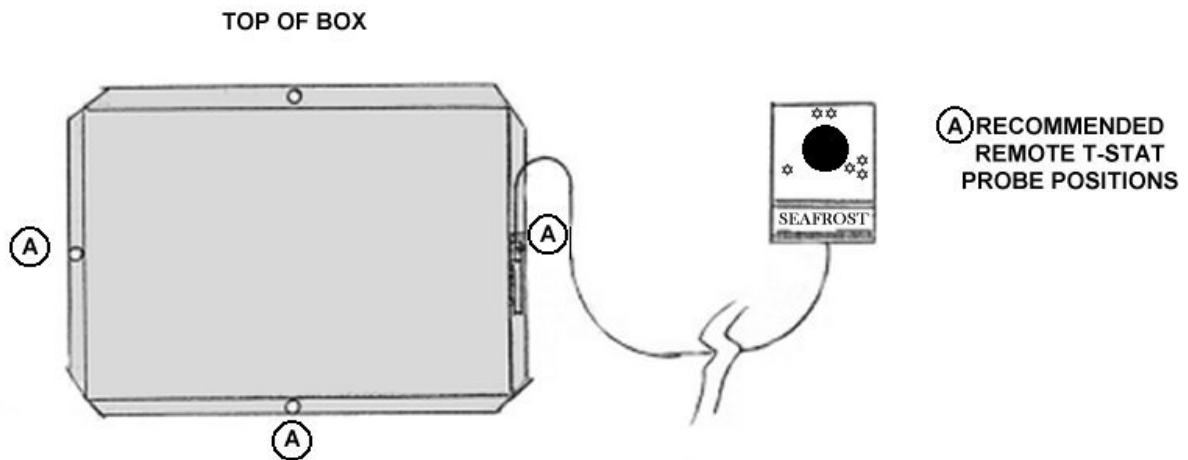

The SEA FROST BD thermostat is variable. Turning the knob fully counterclockwise turns the unit "OFF". The fully clockwise setting is the coldest (three snowflakes). The thermostat may be adjusted to obtain any temperature desired in the cabinet. The thermostat may be calibrated should the warmest setting be too cold. To calibrate the thermostat remove the mounting screws and tip the panel forward. Remove the electrical tape to expose a black torx adjustment screw about an inch into the case.

Remote Thermostat Calibration

The thermostat may be calibrated should the warmest setting be too cold. To calibrate the thermostat remove the mounting screws and tip the panel forward. Remove the electrical tape (if necessary) to expose a black torx adjustment screw about an inch into the case.

To lower box temperature, rotate this screw counter clockwise. One full revolution will change the box temperature approximately 6 degrees F. To raise the temperature in the box rotate the screw clockwise. Make small adjustments. Record all adjustments.

OPERATION DESCRIPTION

Once installed the BD is started by turning the thermostat clockwise from the off position. The BD will run until the plate reaches the set temperature of the thermostat. Turning the thermostat clockwise lowers the temperature at which the BD will switch off. The BD will remain off until the plate temperature rises about 6 degrees. (The BD is either on or off. It will not cool faster with a colder setting.)

The SEA FROST BD is a small system. It is efficient in its electrical conversion of energy to heat movement. By being small it is quiet, compact, has low electrical starting requirements and running power draw, and is able to be air-cooled. It will take some time to cool a warm cabinet.

Pump Operation: The water pump has a switch on the left end of the compressor cabinet. The on switch position for the pump is up. With the pump switch on the pump will operated automatically when the compressor starts.

Switch off the pump when the refrigeration demand is low. This will extend the life of the pump. Be sure the pump is switched off when dockside, when motoring and when hauled.

DEFROSTING

Excessive frost/ice build up on the plate will reduce the cooling effect by insulating the evaporator plate. Allowing the evaporator plate to warm above freezing is one method of defrosting. Boiling water or a scraper will also work.

OPERATION INSPECTION

Within a few minutes of starting the Sea Frost BD, the tubing in close proximity to the valve mounted on the plate and the valve itself will be noticeably cold. **IF AFTER 20 MINUTES OF OPERATION, COOLING IN THIS AREA IS NOT OBSERVED DO NOT CONTINUE TO OPERATE THE SYSTEM.**

IMPORTANT: When using the water pump, check water flow and periodically inspect and clean the seawater strainer.

OPERATIONAL INFORMATION

VOLTAGE	12 D.C. or 24 D.C.
AMP/HR DRAW	4.5 TO 6 @ 12 VOLTS PUMP ADDS 1 AMP/HR
PEAK AMP/HR START (12 volt)	14
LOW VOLTAGE CUT OFF	10.4 VOLTS @ 12 VOLTS 22.8 VOLTS @ 24 VOLTS
WIRE SIZE TO BATTERY SUPPLY	AWG # 10 TO 10 FEET
	AWG # 8 MAXIMUM 25 FEET
FUSE:	15 AMP MAX MUST BE INSTALLED AT BATTERY

SERVICE NOTE: The BD is intended to operate with the cover in place. When monitoring operating with gauges, be sure to block off the top and front with cardboard and tape to maintain proper airflow to the condenser.

WATER COOLED MAINTENANCE

Drain all water from the pump, sea strainer, hoses and water coil in the BD housing when entering a freezing climate. Switch off the pump to avoid dry pump operation.

TROUBLESHOOTING

A light emitting diode (LED) is connected between terminals **+** and **D**. In case the electronic unit records an operational error, the diode will flash a number of times. The number of flashes depends on what kind of operational error was recorded. Each flash lasts 1/4 second. After the actual number of flashes there will be a delay with no flashes, the sequence for each error recording is repeated every 4 seconds. Flashes will only occur in the fault mode with the system on.

OPERATIONAL ERRORS SHOWN BY LED

umber of flashes	Error type
5	Thermal cut-out of electronic unit (If the refrigeration system has been too heavily loaded, or if the ambient temperature is high, the electronic unit will run too hot).
4	Minimum motor speed error (If the refrigeration system is too heavily loaded, the motor cannot maintain minimum speed 1,850 rpm).
3	Motor start error (The system is overcharged).
2	Fan over-current cut-out (The fan is defective).
1	Battery protection cut-out (The voltage is outside the cut-out setting. Low voltage.)

BD Air-Water Wiring

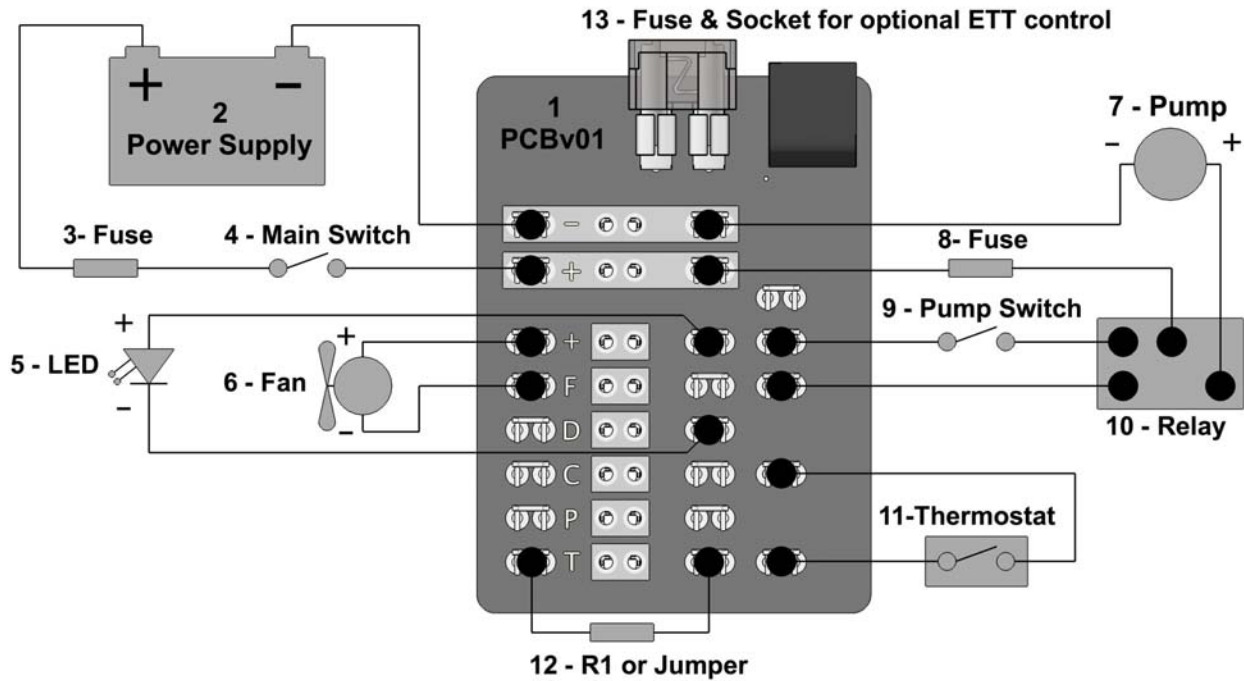

NOTE: When using the modular thermostat connection (#13) there are no connections on thermostat terminals (#11).

<ul style="list-style-type: none"> 1. Electronic unit 2. Battery 3. Fuse (see electrical connections) 4. Main switch (optional) 5. LED for operational errors 6. Fan 7. Pump 8. Fuse 	<ul style="list-style-type: none"> 9. Pump Switch 10. Relay 11. Thermostat 12. R1- Resister for pre-setting speed (optional) or Jumper for AEO module 13. RJ45 jack for optional Electronic Thermostat.
--	--

NOTE

1. THE PUMP IS NOT SELF-PRIMING.
MOUNT BELOW THE WATERLINE.
2. THE PUMP MUST BE MOUNTED ABOVE
THE STRAINER AND THRU HULL.
3. ARRANGE COMPONENTS SO AIR
CANNOT BE TRAPPED IN LINES.

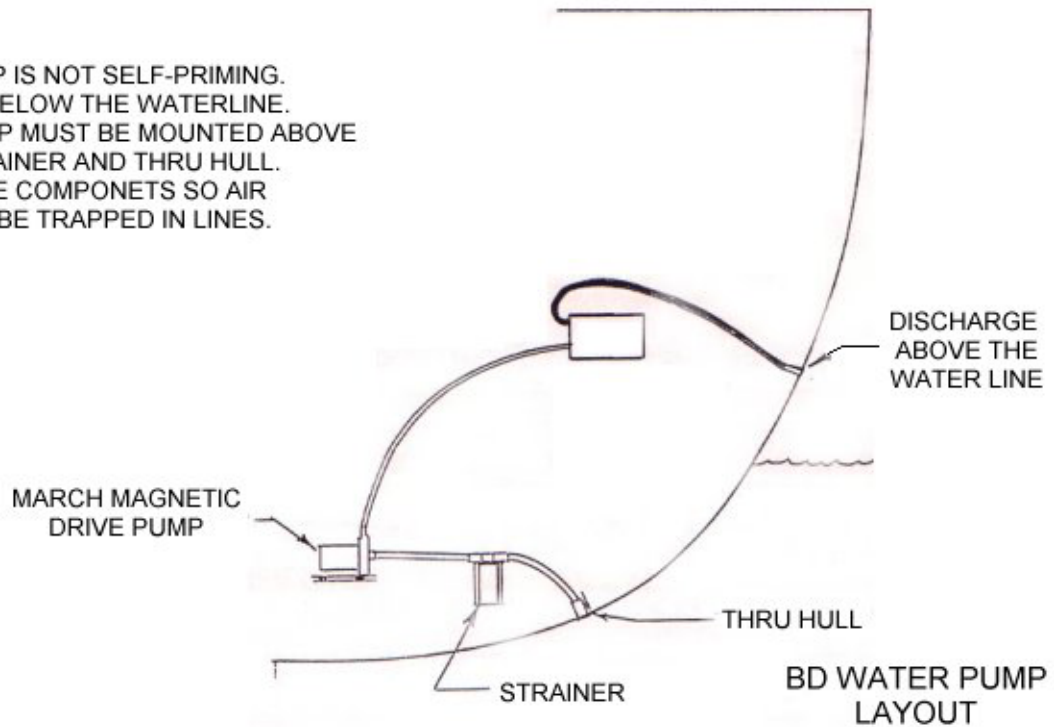

AVAILABLE OPTIONS

- Remote Thermostat Panel Kit
- Speed Control Panel Kit
- Speed Control with Remote Thermostat Combination Panel Kit
- Electronic Thermostat Thermometer Panel Kit
- Remote Dial Thermometer
- 4" Vent Hose
- 4" Vent Grill
- Ice Tray Kit
- Bulkhead Mounting Brackets
- Bin Lid for Freezer Bin
- Water Cooling Option
- Water Pump

Our Repair Policy

Your **Sea Frost BD** system is manufactured to the highest standards and thoroughly tested. If you experience problems with your system requiring technical service, return it to us freight prepaid.

When a system is returned to us we will fix manufacturing defects and failures occurring in normal operation for one year from the date of purchase at no charge, and return it to you freight prepaid (surface freight) anywhere in the continental United States. Installation damage and damage to the electrical parts will be favorably considered however this damage is not our responsibility.

Improper wiring, improper voltage, corrosion, and water damage are not considered manufacturing defects. It is your job to install and maintain your system in a reasonable manner to prevent possible problems.

Proper installation and reasonable care will give you many years of excellent operation. Please notify us before returning your system for repair.

SEA FROST
372 ROUTE 4
373 BARRINGTON, NH 03825
(800) 435-6708 (603) 868-5720